

INSTRUCTION MANUAL

CRT READOUT / DIGITAL
OSCILLOSCOPE / OSCILLOSCOPE

MODELS

COM7200A / COM7201E
COM7100A (AGP) / COM7101E
COM7060A (AGP) / COM7061A

First Edition

KIKUSUI ELECTRONICS CORPORATION

(KIKUSUI PART NO. Z1-512-720)

885620

On Power Supply Source, it is requested to replace the related places in the instruction manual with the following items.

(Please apply the item of mark.)

- Power Supply Voltage: to _ _ _ _ _ V AC
- Line Fuse: to _ _ _ _ _ A
- Power Cable: to 3-core cable (See Fig. 1 for the colors.)

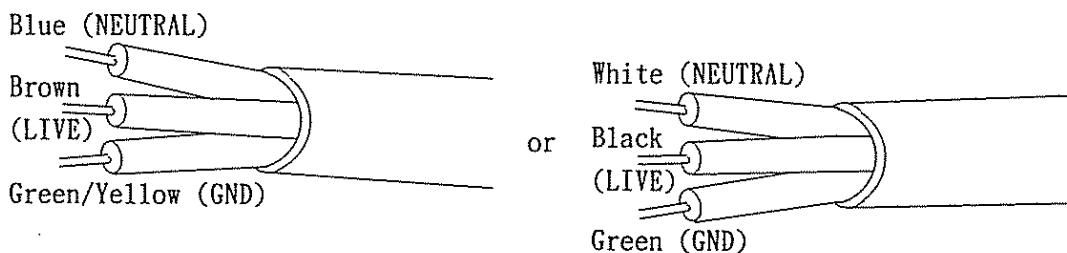

Fig. 1

Please be advised beforehand that the above matter may cause some alteration against explanation or circuit diagram in the instruction manual.

* AC Plug: In case of Line Voltage 125V AC or more, AC Plug is in principle taken off and delivered, in view of the safety.

(AC Plug on 3-core cable is taken off in regardless of input voltages.)

TO connect the AC plug to the AC power cord, connect the respective pins of the AC plug to the respective core-wires (LIVE, NEUTRAL, and GND) of the AC power cord by referring to the color codes shown in Fig. 1.

Before using the instrument, it is requested to fix a suitable plug for the voltage used.

90. H. 17

905181

TABLE OF CONTENTS

	<u>PAGE</u>
1. GENERAL	1-1
1.1 Description	1-1
1.2 Features	1-2
2. SPECIFICATIONS	2-1
3. PRECAUTIONS BEFORE OPERATING THE OSCILLOSCOPE	3-1
3.1 Unpacking the oscilloscope	3-1
3.2 Environments	3-1
3.3 CRT Intensity	3-1
3.4 Maximum Safe Input Voltages	3-1
4. OPERATING	4-1
4.1 Description of Front Panel	4-1
4.2 Description of Front Panel (for Storage Mode)	4-21
4.3 Description of Rear Panel	4-30
* Front Panel of COM7200A	4-32
* Front Panel of COM7201E	4-33
* Rear Panel	4-34
4.4 Description of CRT Readout	4-35
4.5 Initial Setting	4-40
4.6 Calibration of Probes	4-41
4.7 To Change Readout Factor for Probe	4-43
4.8 Beam Finder	4-43
4.9 2-channel Mode	4-43
4.10 ADD Mode	4-44
4.11 X-Y Mode	4-45
4.12 3-channel or 4-channel Mode	4-45
4.13 Voltage Measurement	4-46
4.14 Voltage Ratio Measurement	4-48
4.15 Time Interval Measurement	4-49
4.16 Time Ratio Measurement	4-50
4.17 Frequency Measurement	4-51
4.18 Measurement of Phase Difference	4-53
4.19 Delayed Sweep	4-54
4.20 Time Interval Measurement with Delayed Sweeps	4-56

885621

	<u>PAGE</u>
5. STORAGE MODE	5-1
5.1 Storage Operation	5-1
5.2 Effective Storage Frequency and Frequency Bandwidth	5-12
5.3 ΔT , $1/\Delta T$ and ΔV Measurement with Cursors	5-15
5.4 DVM and Frequency Counter	5-15
5.5 Delayed Sweep	5-15
5.6 PENOUT Signal	5-16
6. GP-IB INTERFACE	6-1
6.1 General	6-1
6.2 GP-IB Specifications	6-3
6.2.1 Standards	6-3
6.2.2 Interface Functions	6-3
6.3 Descriptions for Operation	6-4
6.3.1 Remote Status and Local Status	6-4
(1) Description of Front Panel and Initial States of Remote mode	6-4
(2) Description of Rear Panel and Setting of Delimiters	6-7
(3) Device Functions	6-10
6.3.2 Command and Data Formats	6-12
(1) Command Format	6-12
(2) Waveform Data Formats and Blocks	6-13
(3) Delimiters	6-14
(4) Abbreviations of Commands	6-14
(5) SRQ and Status Byte	6-15
6.3.3 Data Send/Receive Sequence	6-16
6.4 Table of Commands	6-18
6.4.1 System Commands	6-21
6.4.2 Commands for vertical Axis	6-23
6.4.3 Commands for Time Base (Horizontal Axis)	6-27
6.4.4 Commands for Triggering	6-31
6.4.5 Commands for Cursors	6-35
6.4.6 Commands for DVM and Counter	6-37
6.4.7 Commands for Step Control	6-38
6.4.8 Commands for Storage	6-39
6.5 Output for GP-IB Plotter	6-45
6.6 Programming Examples	6-47

885622

	<u>PAGE</u>
6.6.1 Examples of Programming for PC-9801 Computer of NEC	6-47
(1) Initial Setting	6-47
(2) Programming Example for Panel Control	6-47
(3) Programming Examples to Read Panel Setting and Measured Values	6-49
(4) Programming Example to modified one of Program (1.3) so that setting of Panel controls also can be done	6-51
(5) Examples of Commands for Control of Cursors and Reading of Measured Values	6-53
(6) Examples of Commands for Control of the DVM and Counter, and Reading of Measured Values	6-53
(7) Examples of Programs for Transfer of Waveform Data	6-54
(8) Step Control	6-57
(9) Example of SRQ Proceesing	6-58
6.6.2 Examples of Programming for Model 9826 Computer of HP	6-60
(1) Initial Setting	6-60
(2) Programming Example for Panel Control	6-60
(3) Programming Examples to Read Panel Setting and Measured Values	6-62
(4) Programming Example to Set Panel Controls and to Read Setting Values	6-64
(5) Examples of Commands for Control of Cursors and Reading of Measured Values	6-66
(6) Examples of Commands for Control of the DVM and Counter, Reading of Measured Values	6-66
(7) Examples of Programs for Transfer of Waveform Data	6-67
(8) Step Control	6-69
(9) Example of SRQ Proceesing	6-71
 7. INITIAL MODE SETTING AND DIAGNOSTIC FUNCTION	 7-1
7.1 Initial Mode Setting	7-1
7.2 Diagnostic Function	7-2
 8. CALIBRATION AND MAINTENANCE	 8-1
8.1 Self Calibration	8-1
8.2 Inspection and Calibration	8-2
8.3 Calibration Procedure	8-2

885623

1. GENERAL

1.1 Description

The COM7xxxA/E Series Oscilloscopes have been designed on new and advanced concepts for accurate, reliable, and easy ways of man-machine communication.

The COM7xxxA/E family is comprised of the following types and models of oscilloscopes:

<u>Types</u>	<u>Models</u>
CRT readout oscilloscopes	COM7200A, COM7100A, COM7060A
Programmable oscilloscopes with GP-IB provision	COM7100AGP, COM7060AGP
Digital oscilloscopes with digital storage function and GP-IB provision	COM7201E, COM7101E, COM7061A

As can be seen in the above listing, suffix "GP" denotes existence/absence of the GP-IB provision. The least significant column ("1"/"0") of the model-number numerals denotes existence/absence of both digital storage function and GP-IB provision at once. Otherwise the oscilloscopes are identical regardless of their type differences, so far as the corresponding model number columns are identical.

The COM7200A has a frequency bandwidth of DC to 200MHz, a maximum deflection factor 1 mV/DIV, and highest sweep rate 1 ns/DIV; the COM7100A has a frequency bandwidth of DC to 100 MHz, a maximum deflection factor of 1 mV/DIV, and highest sweep rate of 2 ns/DIV; the COM7060A has a frequency bandwidth of DC to 60 MHz, a maximum deflection factor of 1 mV/DIV, and highest sweep rate of 5 ns/DIV.

885624

1.2 Features

The features of the COM7200A representing the CRT readout oscilloscopes and the COM7201E representing the digital oscilloscopes are as follows.

A. Features of COM7200A/COM7201E

(1) CRT readout

Various items of information concerning measurement, together with the signal waveform to be measured, are displayed on the CRT for accurate and rapid measurement. The displayed items include the vertical deflection factor, input coupling mode, timebase sweep rate and delay time, and the value determined between cursors and the values measured by the internal voltmeter and frequency counter.

(2) 4-channel display

The oscilloscope employs a multi-mode select system which allows you to select any combination of the four channels. All of the four channels provide the specified highest frequency range either at the BNC input terminals or at the probe tips.

(3) Measurement with cursors

Two cursors are displayed on the CRT. As you move these cursors to the points of measurement, the differential voltage, period or phase between the two points is automatically determined and readout displayed on the CRT, eliminating the chance of human reading error and calculation mistakes. When in the tracking mode the two cursors can be translated keeping the distance between them constant, allowing you to compare amplitudes and periods very conveniently.

885625

(4) Functions of digital voltmeter and frequency counter

The oscilloscope has a digital voltmeter circuit and a frequency counter circuit. The digital voltmeter is a 3-1/2-digit digital multimeter which measures the DC voltage, AC rms voltage or peak-to-peak voltage of the signal applied to the input terminal of channel 1.

The frequency counter is a 4-digit auto-range counter which measures the frequency of the trigger signal selected by the trigger source switch. The measured values are displayed on the CRT.

(5) Full employment of IC's and calibration verification feature

A number of newly developed IC's are employed for most part of the major circuits of the oscilloscope, thereby reducing the number of discrete components to the minimum and improving the reliability and maintainability. The circuits are self-calibrated for reliable measurement.

(6) Ease of operation

The panel switches and controls are laid out for most efficient and easy operation. The major functions are selectable by simple operation of individual switches, while less frequently used switches and controls are collectively located and classified by the natures of their functions, thereby making the instrument panel neat and highly functional.

(7) Memory for panel setting

All data of the panel settings are stored in the internal memory of the oscilloscope and are not lost even when the power is turned off. When the power switch is turned on again, the panel settings are automatically restored relieving you from resetting the panel controls each time the power switch is turned on.

885626

(8) Compact and light

The oscilloscope is very compact and light for its high performance and reliability. It is 31.8 cm (12.5 in.) wide, 15.0 cm (5.91 in.) high, 40.0 cm (15.7 in.) deep, and weighs 8 kg (18 lbs) for COM7200A or 10 kg (22 lbs) for COM7201E.

(9) 50-ohm input circuits

The input impedance of channels 1 and 2 of COM7200A/COM7201E is selectable between 1 meg-ohms and 50 ohms. The 50-ohm input circuits are incorporated with an overvoltage protector.

(10) CRT with bright and sharp images

All of the COM7xxxA/E Series Oscilloscopes employ a 20-kV CRT that display bright and sharp images even for rapidly changing phenomena. (No "MICROCHANNEL-PLATE" are used.)

(11) On any line voltage

The COM7xxxA/E Series Oscilloscopes operate on any AC line voltage within a range of 90 to 250 V AC without requiring any switching procedure. Since they employ no large power transformer, they are compact and light.

Although the Oscilloscopes have not been officially approved yet by any public organizations for standards or specifications, evaluation tests performed by the manufacture indicated that the Oscilloscopes reliably operate for wide ambient temperature and humidity ranges of 0 to 50 deg. C (32 to 122 deg. F) and up to 95% RH.

(12) Automatic triggering level control, requiring no manual adjustment

(13) 4-channel alternate triggering, allowing successful triggering of input signals of different frequencies

885027

- (14) A TV synchronizing separator for TV.V or TV.H selection
- (15) A linear focus control circuit, requiring no manual focus adjustment each time intensity is varied
- (16) 3-channel X-Y operation

B. Features of COM7201E, COM7101E, COM7061A (Digital Storage Section)

- (17) Sampling rate up to 20 MS/sec

The maximum sampling rate is as fast as 20 MS/sec and the vertical resolution is as high as 8 bits, allowing you to capture one-shot phenomena of up to 8 MHz.

- (18) Digitizing of signals of up to 100 MHz

In the equivalent sampling mode, signals of up to 100 MHz can be successfully captured. The equivalent sampling rate in this case is as high as 10 GS/sec. (COM7201E)

The COM7061A is able to capture signals of up to 60 MHz.

- (19) Envelope mode to detect one-shot glitches as fast to 20 ns

The oscilloscope has a peak-value detector circuit which is able to capture a pulse of narrow duration of down to 20 ns within a sampling clock period and to display the maximum and minimum values. Thus the circuit allows detection of narrow pulses involved in a slowly changing repetitive signal and, even when the input signal frequency has become higher than one-half of the sampling frequency, aliasing that may cause measuring errors can be discriminated.

(20) Reference memory to store up to four waveforms

The storage section has a reference memory (other than the display memory) for up to four waveforms which can be re-written as required. The reference memory is internally backed up and the stored data can be maintained for a long period.

(21) GP-IB interface functions

The oscilloscope is compatible with the GP-IB interface system, allowing programmed remote control of the oscilloscope and transfer of status data displayed on the CRT readout or waveform data stored in memory. A hardcopy of data can be readily obtained by calling out a GP-IB plotter with a HP-GL command.

(22) Various functions with digital storage

Various advantageous functions are realized with the digital storage, such as pretriggering for viewing of signal waveform preceding the trigger point, interpolation which provides a convenient means for measurement of high-speed one-shot phenomenon, expansion of time base up to 100 times for stored signal magnification, roll mode which is convenient for monitoring of a low-speed continuous signal, and delayed magnification which allows high speed sampling of any portion of a signal sampled at a slow rate.

(23) Programmable oscilloscope

By using Remote Controller RCO1-COM, the oscilloscope can be used as a programmable instrument. Up to 100 items of panel settings can be programmed and called by simple panel key operation.

By using Probe Selector PSO1-COM, up to 16 probes (8 probes for each of CH1 and CH2) can be connected to the oscilloscope making up an instrument of 16 input channels. The probes are selectable with the Remote Controller.

885629

2. SPECIFICATIONS

o Vertical Axes

Item	Specification	Remarks
CH1, CH2		
Deflection Factor	1 mV/DIV to 5 V/DIV	1-2-5 sequence, 12 ranges
Accuracy of Deflection Factor	5 mV/DIV to 5 V/DIV: $\pm 2\%$ 1 mV/DIV and 2 mV/DIV: $\pm 4\%$	15 to 35°C (59 to 95°F) 1 kHz, 4 - 5 DIV reference
Vernier Control of Deflection Factor	Continuously variable attenuation to 1/2.5 or less of set value	
Frequency Bandwidth	COM7201E, COM7200A DC to 200 MHz, within -3 dB DC to 50 MHz, within -3 dB (1 mV/DIV, 2 mV/DIV) Low limit frequency of AC coupling: 10 Hz	50kHz, 8 DIV reference 15 to 35°C (59 to 95°F) COM7201E: When in real mode
	COM7101E, COM7100A DC to 100 MHz, within -3 dB DC to 30 MHz, within -3 dB (1 mV/DIV, 2 mV/DIV) Low limit frequency of AC coupling: 10 Hz	50 kHz, 8 DIV reference 15 to 35°C (59 to 95°F) COM7101E: When in real mode
	COM7061A, COM7060A DC to 60 MHz, within -3 dB DC to 30 MHz, within -3 dB (1 mV/DIV, 2 mV/DIV) Low limit frequency of AC coupling: 10 Hz	50 kHz, 8 DIV reference 15 to 35°C (59 to 95°F) COM7061A: When in real mode
Input Impedance	COM7201E, COM7200A 1 M Ω $\pm 1\%$, 18 pF ± 3 pF, 50 Ω $\pm 2\%$	
	COM7101E, COM7100A, COM7061A, COM7060A 1 M Ω $\pm 1\%$, 20 pF ± 3 pF,	

885630

Item	Specification	Remarks
CH3, CH4,		
Deflection Factor	0.1 V/DIV, 0.5 V/DIV	2 ranges
Accuracy of Deflection Factor	±5%	15 to 35°C (59 to 95°F) 1 kHz, 4 - 5 DIV reference
Frequency Bandwidth	COM7201E, COM7200A DC to 200 MHz, within -3 dB Low limit frequency of AC coupling: 10 Hz	50 kHz, 8 DIV reference 15 to 35°C (59 to 95°F) COM7201E: When in real mode
	COM7101E, COM7100A DC to 100 MHz, within -3 dB Low limit frequency of AC coupling: 10 Hz	50 kHz, 8 DIV reference 15 to 35°C (59 to 95°F) COM7101E: When in real mode
	COM7061A, COM7060A DC to 60 MHz, within -3 dB Low limit frequency of AC coupling: 10 Hz	50 kHz, 8 DIV reference 15 to 35°C (59 to 95°F) COM7061A: When in real mode
Input Impedance	COM7201E, COM7200A 1 MΩ ±1%, 18 pF ±3 pF,	
	COM7101E, COM7100A, COM7061A, COM7060A 1 MΩ ±1%, 20 pF ±3 pF,	
Maximum Safe Input Voltage	1 MΩ circuit: 400 V _{peak} (DC + AC peak) 50 Ω circuit (CH1 and CH2 only of COM7201E, COM7200A): 5 V (with overvoltage protector)	AC components not higher than 1 kHz
Input Coupling	AC, GND, DC	
Rise Time	COM7201E, COM7200A Approx. 1.75 ns Approx. 7 ns (1 mV/DIV, 2 mV/DIV)	Theoretical values When in real mode
	COM7101E, COM7100A Approx. 3.5 ns Approx. 11.7 ns (1 mV/DIV, 2 mV/DIV)	Theoretical values When in real mode

885631

Item	Specification	Remarks
Rise Time (cont'd)	COM7061A, COM7060A Approx. 5.8 ns Approx. 11.7 ns (1 mV/DIV, 2 mV/DIV)	Theoretical values When in real mode
Channel Modes	CH1, ADD (CH1 + CH2), CH2 CH3, CH4 Any combination of the above channels in a multi-mode select system. X-Y display with CH1 as X and any one or ones of CH2, CH3 and CH4 as Y.	
Time Difference Among Channels	<±500 ps (of all channels)	(Except 1 mV/DIV, 2 mV/DIV ranges)
Signal Delay Time	Approx. 40 ns	
Chop Frequency	Approx. 1 MHz	
Bandwidth Limiter	20 MHz ±5 MHz, -3 dB	
Polarity Select	For CH2 only	
CH1 Signal Output	Approx. 50 mV/DIV when output terminal is open	
	Approx. 25 mV/DIV when output terminal is terminated with 50Ω	COM7201E, COM7200A COM7101E, COM7100A DC to 100 MHz -3dB. COM7061A, COM7060A DC to 60 MHz -3dB.

o Triggering

Item	Specification	Remarks
A Trigger		
Triggering Signal Sources	CH1, CH2, CH3, CH4, LINE, and V-MODE (When in V-MODE, channels operating in VERT mode are used as signal sources. When in ADD mode, CH1 is used as signal source. When in CHOP mode or AUTO LEVEL mode, the leftmost one of the operating channels indicated by VERT mode lamps on panel is used as signal source.)	V-MODE is effective when in ALT SWEEP mode or SINGLE SWEEP mode or when AUTO LEVEL mode is released
Coupling	AC, LF.REJ, HF.REJ, DC, TV.V, and TV.H	
Polarity	+ or -	
Sensitivity	COM7201E, COM7200A DC to 10 MHz: 0.4 DIV DC to 200 MHz: 1.5 DIV TV.V, TV.H: 1.0 DIV AC: Attenuates signal components of 10 Hz and lower LF.REJ: Attenuates signal components of 50 kHz and lower HF. REJ: Attenuates signal components of 50 kHz and higher	TV.V, TV.H: When in NTSC full field color bar signal
	COM7101E, COM7100A DC to 10 MHz: 0.4 DIV DC to 100 MHz: 1.5 DIV TV.V, TV.H: 1.0 DIV AC: Attenuates signal components of 10 Hz and lower	TV.V, TV.H: When in NTSC full field color bar signal

885633

Item	Specification	Remarks
Sensitivity (cont'd)	LF.REJ: Attenuates signal components of 50 kHz and lower HF.REJ: Attenuates signal components of 50 kHz and higher	
	COM7061A, COM7060A DC to 10 MHz: 0.4 DIV DC to 60 MHz: 1.5 DIV TV.V, TV.H: 1.0 DIV AC: Attenuates signal components of 10 Hz and lower LF.REJ: Attenuates signal components of 50 kHz and lower HF.REJ: Attenuates signal components of 50 kHz and higher	TV.V, TV.H: When in NTSC full field color bar signal
AUTO LEVEL	Satisfies the above values with 0.5 DIV added to each of them	For sinusoidal waves
Modes	AUTO: When no triggering signal is applied, sweep runs automatically. NORM: When no triggering signal is applied, sweep is in a ready state and does not run. SINGLE: When triggering signal is applied, sweep runs only once. When RESET key is pressed, sweep is reset to READY state. When in READY state or sweeping, READY lamp illuminates	When in real mode of COM7201E, COM7101E, COM7061A

885634

Item	Specification	Remarks
B Trigger		
Triggering Signal Sources	CH1, CH2, CH3, CH4, and V-MODE (When in V-MODE, channels operating in VERT mode are used as signal sources. When in ADD mode, CH1 is used as signal source. When in CHOP mode or AUTO LEVEL mode, the leftmost one of the operating channels indicated by VERT mode lamps on panel is used as signal source.)	V-MODE is effective when in ALT SWEEP mode or SINGLE SWEEP mode or when AUTO LEVEL mode is released.
Coupling	AC, LF.REJ, HF.REJ, and DC	
Polarity	+ or -	
Sensitivity	COM7201E, COM7200A DC to 10 MHz: 0.4 DIV DC to 200 MHz: 1.5 DIV AC: Attenuates signal components of 10 Hz and lower LF.REJ: Attenuates signal components of 50 kHz and lower HF.REJ: Attenuates signal components of 50 kHz and higher	
	COM7101E, COM7100A DC to 10 MHz: 0.4 DIV DC to 100 MHz: 1.5 DIV AC: Attenuates signal components of 10 Hz and lower LF.REJ: Attenuates signal components of 50 kHz and lower HF.REJ: Attenuates signal components of 50 kHz and higher	

885635

Item	Specification	Remarks
Sensitivity (cont'd)	COM7061A, COM7060A DC to 10 MHz: 0.4 DIV DC to 60 MHz: 1.5 DIV AC: Attenuates signal components of 10 Hz and lower LF.REJ: Attenuates signal components of 50 kHz and lower HF.REJ: Attenuates signal components of 50 kHz and higher	
AUTO LEVEL	Satisfies the above values with 0.5 DIV added to each of them	For sinusoidal waves

885636

o Time Base (Horizontal Axis)

Item	Specification	Remarks
A Sweep		
Sweep Speeds	COM7201E Real mode: 10 ns/DIV to 0.5 s/DIV Storage mode: 10 ns/DIV to 5 s/DIV	1-2-5 sequence
	COM7200A 10 ns/DIV to 0.5 s/DIV	1-2-5 sequence
	COM7101E Real mode: 20 ns/DIV to 0.5 s/DIV Storage mode: 20 ns/DIV to 5 s/DIV	1-2-5 sequence
	COM7100A 20 ns/DIV to 0.5 s/DIV	1-2-5 sequence
	COM7061A Real mode: 50 ns/DIV to 0.5 s/DIV Storage mode: 50 ns/DIV to 5 s/DIV	1-2-5 sequence
	COM7060A 50 ns/DIV to 0.5 s/DIV	1-2-5 sequence
	Accuracy of Sweep Speeds	±2%
Vernier Control of Sweep Speeds	Continuously variable to a speed slower by 2.5 times or more of set value	When in real mode of COM7201E, COM7101E, COM7061A
Variable Holdoff	Provided	When in real mode of COM7201E, COM7101E, COM7061A

885437

Item	Specification	Remarks
B Sweep		
Sweep Speeds	COM7201E Real mode: 10 ns/DIV to 0.5 s/DIV Storage mode: 10 ns/DIV to 50 ms/DIV	1-2-5 sequence
	COM7200A 10 ns/DIV to 0.5 s/DIV	1-2-5 sequence
	COM7101E Real mode: 20 ns/DIV to 0.5 s/DIV Storage mode: 20 ns/DIV to 50 ms/DIV	1-2-5 sequence
	COM7100A 20 ns/DIV to 0.5 s/DIV	1-2-5 sequence
	COM7061A Real mode: 50 ns/DIV to 0.5 s/DIV Storage mode: 50 ns/DIV to 50 ms/DIV	1-2-5 sequence
	COM7060A 50 ns/DIV to 0.5 s/DIV	1-2-5 sequence
	Accuracy of Sweep Speeds	±2%
Delayed Sweep		
Type of Sweep	Continuous delay, triggered delay	
Delay Jitter	< 1/10,000	

885638

Item	Specification	Remarks
Sweep Magnification	10 times COM7201E, COM7200A Maximum sweep speed: 1 ns/DIV COM7101E, COM7100A Maximum sweep speed: 2 ns/DIV COM7061A, COM7060A Maximum sweep speed: 5 ns/DIV	When in ALT mode, B sweep alone is magnified.
Accuracy of Sweep Magnification	COM7201E 5 ns/DIV to 0.5 s/DIV: $\pm 4\%$ 1 ns/DIV, 2 ns/DIV: $\pm 8\%$ COM7200A 5 ns/DIV to 50 ms/DIV: $\pm 4\%$ 1 ns/DIV, 2 ns/DIV: $\pm 8\%$ COM7101E 5 ns/DIV to 0.5 s/DIV: $\pm 4\%$ 2 ns/DIV: $\pm 8\%$ COM7100A 5 ns/DIV to 50 ms/DIV: $\pm 4\%$ 2 ns/DIV: $\pm 8\%$ COM7061A 5 ns/DIV to 0.5 s/DIV: $\pm 4\%$ COM7060A 5 ns/DIV to 50 ms/DIV: $\pm 4\%$	15 to 35°C (59 to 95°F) For 8 DIV at center of CRT. Excluding 10% portions at both ends of sweep.

885639

Item	Specification	Remarks
X-Y Mode		When in real mode of COM7201E, COM7101E, COM7061A
Channels for Axes	X-axis: CH1 Y-axes: CH2, CH3, CH4 (X-Y operation of up to 3 channels)	Y-axis: CHOP mode
Deflection Factor	Identical with those of CH1, CH2, CH3, and CH4	
Accuracy of Deflection Factor	X-axis: $\pm 3\%$ (5 mV/DIV to 5 V/DIV) $\pm 5\%$ (1 mV/DIV, 2 mV/DIV) Y-axes: $\pm 2\%$ (CH2) $\pm 5\%$ (CH3, CH4)	15 to 35°C (59 to 95°F) 1 kHz, 4 - 5 DIV reference
Frequency Bandwidth	COM7201E, COM7200A DC to 4 MHz, within -3dB	X-axis: For CH1 Y-axes: Identical with CH2, CH3, CH4
	COM7101E, COM7100A, COM7061A, COM7060A DC to 2 MHz, within -3dB	
X-Y Phase Difference	COM7201E, COM7200A < 3° (DC to 200 kHz)	
	COM7101E, COM7100A, COM7061A, COM7060A < 3° (DC to 100 kHz)	

o CRT Readout

Item	Specification	Remarks
Setting Display	CH1, CH2, CH3, CH4 scale factors and coupling modes CH1, CH2, UNCAL status Use of 10:1 probe A sweep, B sweep scale factors A sweep UNCAL status Holdoff, bandwidth limiter status Δ REF cursor, Δ cursor Delay time, Δ T, $1/\Delta$ T, Δ V, voltage ratio Time ratio, phase difference, frequency counter reading, DVM reading (AC, DC, p-p)	For COM7201E, COM7101E, COM7061A in real mode, and for COM7200A, COM7100A, COM7060A
	CH1, CH2, CH3, CH4 scale factors and coupling modes CH1, CH2, UNCAL status Use of 10:1 probe A sweep, B sweep scale factors Bandwidth limiter status Δ REF cursor, Δ cursor Delay time, Δ T, $1/\Delta$ T, Δ V, voltage ratio Scale factors and coupling modes of reference memory units 1 - 4 Reference memory time base scale factor, pre-delayed trigger point, magnification point, delayed start point, view time	For COM7201E, COM7101E, COM7061A in storage mode,
DLY	Delay time and Δ T display	
Delay Time Range	0.50 to 10.00 times of A sweep setting of highest sweep speed range to 0.5 s/DIV range	
Δ T Accuracy	$\pm 2\%$ (when in the time intervals measured with delayed B SWEEP)	

885641

Item	Specification	Remarks
ΔT	Time interval between Δ REF cursor and Δ cursor is displayed.	
Measuring Range	± 4.6 DIV or more from center of CRT	
Measuring Accuracy	$\pm (3\% \text{ of reading} + 0.05 \text{ DIV})$	$\times 10$ MAG off
$1/\Delta T$	Reciprocal (frequency) of ΔT is displayed.	
ΔV	Voltage between Δ REF cursor and Δ cursor is displayed.	When in CH2 SINGLE SWEEP mode or when in CH2 and CH3/CH4 channel modes, scale factor is as that of CH2; in other cases, scale factor is as that of CH1.
Measuring Range	± 3.6 DIV or more from center of CRT	
Measuring Accuracy	$\pm (3\% \text{ of reading} + 0.05 \text{ DIV})$	
Time Ratio	Displays the ratio of time interval between Δ REF cursor and Δ cursor with respect to 5 DIV on CRT as reference (100%).	When in ΔT measurement, SWEEP VARIABLE is displayed in UNCAL status.
Measuring Range	± 4.6 DIV or more from center of CRT	
Measuring Accuracy	$\pm (3\% \text{ of reading} + 0.05 \text{ DIV})$	$\times 10$ MAG off
Phase Difference	Displays in degrees the phase difference between Δ REF cursor and Δ cursor with respect to 5 DIV on CRT as reference (360 degrees).	When in $1/\Delta T$ measurement, SWEEP VARIABLE is displayed in UNCAL status
Measuring Range	± 4.6 DIV or more from center of CRT	
Measuring Accuracy	$\pm (3\% \text{ of reading} + 0.05 \text{ DIV})$	$\times 10$ MAG off

Item	Specification	Remarks
Voltage Ratio	Displays the ratio of voltage between Δ REF cursor and Δ cursor with respect to 5 DIV on CRT as reference (100%).	When in Δ V measurement, GAIN VARIABLE is displayed in UNCAL status.
Measuring Range	± 3.6 DIV or more from center of CRT	
Measuring Accuracy	$\pm(3\%$ of reading + 0.05 DIV)	
Δ Delay	Measures ΔT or $1/\Delta T$ by using B sweep instead of Δ REF cursor and Δ cursor.	Operates in ALT sweep and B sweep modes at the same time.
Measuring Range	3.6 DIV or more to right and left from center of CRT	
Measuring Accuracy	$\pm(2\%$ of reading + 0.05 DIV) (Excluding 0.5 DIV from left hand end of CRT)	$\times 10$ MAG off
DVM	Displays with 3-1/2 digits in the CH1 input for up to ± 7 DIV on CRT (AC voltage, DC voltage, p-p voltage)	Not effective when in storage mode of COM7201E, COM7101E, COM7061A
AC	Measures AC voltage in rms value for 20 Hz to 100 kHz Measuring accuracy: $\pm 4\%$	Tcal $\pm 5^\circ\text{C}$, for 4 DIV at center of CRT. (Note)
DC	Measures DC voltage Measuring accuracy: $\pm 3\%$	Tcal $\pm 5^\circ\text{C}$, for 4 DIV at center of CRT. (Note)
p-p	Measures peak-to-peak voltage for 20 Hz to 10 MHz Measuring accuracy: 20 Hz to 5 MHz: $\pm 5\%$ 5 MHz to 10 MHz: $\pm 10\%$	Tcal $\pm 5^\circ\text{C}$, for 4 DIV at center of CRT. (Note)

(Note) Tcal: 20 to 30°C after using internal auto calibration check

885643

Item	Specification	Remarks
FREQ	Measures frequency of input channel signal selected by TRIG SOURCE switch. 4-digit display, auto-range	Displays at the same time with DVM. Not effective when two or more triggering source signals are selected.
Measuring Ranges	COM7201E, COM7200A: 1 Hz to 200 MHz	
	COM7101E, COM7100A: 1 Hz to 100 MHz	
	COM7061A, COM7060A: 1 Hz to 80 MHz	
Measuring Accuracy	±0.1%	

885644

o Storage Mode (COM7201E, COM7101E, COM7061A)

Item	Specification	Remarks
Vertical Axis Resolution	8 bits (25 points/DIV)	
Time Base (Horizontal Axis) Resolution	10 bits (100 points/DIV)	
Sampling Rates	20 samples/sec to 20M samples/sec	
Accuracy of Sampling Rate	0.02%	
Accuracy of Deflection Factor	CH1, CH2 5 mV/DIV to 5 V/DIV: $\pm(2\% + 1 \text{ LSB})$ 1 mV/DIV, 2 mV/DIV: $\pm(4\% + 1 \text{ LSB})$ CH3, CH4 $\pm(5\% + 1 \text{ LSB})$	15 to 35°C (59 to 95°F) 1kHz, 4 - 5 DIV reference
Frequency Bandwidth	COM7201E, COM7101E DC to 100 MHz, within -3 dB DC to 50 MHz, within -3 dB (1 mV/DIV, 2 mV/DIV)	15 to 35°C (59 to 95°F) 50 kHz, 8 DIV reference
	COM7061A DC to 60 MHz, within -3 dB DC to 30 MHz, within -3 dB (1 mV/DIV, 2 mV/DIV)	15 to 35°C (59 to 95°F) 50 kHz, 8 DIV reference
Effective Storage Frequency	COM7201E, COM7101E 8 MHz: When in SINGLE SWEEP mode with 5 $\mu\text{s}/\text{DIV}$ or faster ranges. 100MHz, -3dB: At time base range for REPEAT mode. For periodic signal.	With sine interpolation
	COM7061A 8 MHz: When in SINGLE SWEEP mode with 5 $\mu\text{s}/\text{DIV}$ or faster ranges. 60 MHz, -3dB: At time base ranges for REPEAT mode. For periodic signal.	With sine interpolation

885645

Item	Specification	Remarks
Effective Rise Time interpolation	COM7201E, COM7101E < 80 ns: When in SINGLE SWEEP mode with 5 μ s/DIV or faster ranges. Approx. 3.5 ns: At time base ranges for REPEAT mode. For periodic signal.	With pulse interpolation
	COM7061A <80 ns: For one-shot signal or non-periodic signals. When in SINGLE SWEEP mode at ranges faster than 5 μ s/DIV. Approx. 5.8 ns: At time base ranges for REPEAT mode. For periodic signal.	With pulse interpolation
Sweep Channels	SINGLE SWEEP: CH1, CH2, CH3, CH4 ALT: Any combination of CH1 through CH4 CHOP: CH1 and CH2	
REPEAT Mode	COM7201E 2 μ s/DIV to 10 ns/DIV	Except when in SINGLE SWEEP mode in random equivalent time sampling
	COM7101E 2 μ s/DIV to 20 ns/DIV	Except when in SINGLE SWEEP mode in random equivalent time sampling
	COM7061A 2 μ s/DIV to 50 ns/DIV	Except when in SINGLE SWEEP mode in random equivalent time sampling
ROLL Mode	5 s/DIV to 0.1 s/DIV automatic operation	When in single channel mode or 2-channel, CHOP mode
ENVELOPE Mode	Operable ranges: 50 ms/DIV to 10 μ s/DIV	

885646

Item	Specification	Remarks
Waveform Magnification	Time base ranges of up to 100 times Reference position for magnification: 0 DIV to 10 DIV, in 1-DIV steps, 11 positions Interpolation: Sine or pulse	When in PAUSE status
Display Memory	(1024 words per channel) ×4	
Reference Memory	For 4 waveforms	Data can be saved in reference memory when in SAVE status.
Pre-triggering	Triggering points: 0, 2, 4, 6, or 8 DIV on CRT	
View Time	0 to approx. 10 sec, 4 steps	

o GP-IB Interface Functions (COM7201E, COM7101E, COM7061A)

Item	Specification	Remarks
Interface Functions (IEEE488-1978) (IEC625)	SH1: All source handshake functions AH1: All acceptor handshake functions T5: Talker function L3: Listener function SR1: All service request functions RL1: All remote/local functions PPO: No parallel poll function DC1: All device clear functions DT0: No device trigger function CO: No control function	COM7201E, COM7101E, COM7061A. GP-IB incorporated models of COM7200A, COM7100A, COM7060A.
Programmable Functions	All functions except VERNIER, FOCUS, and TRACE ROTATION	
Formats	Device commands: ASCII Waveform data: Binary or ASCII (selectable)	Waveform data is for COM7201E, COM7101E and COM7061A only

885647

o Programmable Control Functions (COM7201E, COM7101E, COM7061A)

Item	Specification	Remarks
Program Steps	100 (00 to 99)	
Programmable Functions	All functions except INTEN, FOCUS, and TRACE ROTATION controls	By using RC01-COM in conjunction. Only for oscilloscopes incorporated with GP-IB functions
Program Backup Functions	Provided	
External Control Functions	Probe selector (PS01-COM)	By using RC01-COM in conjunction.
Remote Controller RC01-COS		
Step Address Display	00 to 99, 7-segment LED's	
Control Functions	COPY: Transfer of data between steps WR: Storing of settings START: Setting of START address END: Setting of END address PROB: Setting of probe number selected by probe selector CONT: VR function selected by RC01-COM RESET: Resetting to START address DEC: Decrement of step address by 1 step INC: Increment of step address by 1 step	
Remote Control Functions	CH1, CH2, CH3 and CH4 vertical positioning and horizontal positioning, REF cursor or DLY positioning, and Δ cursor positioning (verniers); automatic step address increment.	
Setting Protective functions	Two types: Instrument panel protect Control function protect	With selector switch
Step Address Output	BCD signal	

885648

o Z-axis

Item	Specification	Remarks
Sensitivity	Intensity modulation discernible with 3 Vp-p input signal. Negative-going signal for brighter trace and positive-going signal for dimmer trace.	
Frequency Range	DC to 10 MHz	
Input Resistance	5 k Ω \pm 10%	
Maximum Safe Input Voltage	50 Vpeak (DC + AC peak)	AC components not higher than 1 kHz

o Signal Outputs

Item	Specification	Remarks
Sweep Signal Output	A sweep signal, approx. 1 Vp-p	BNC terminal at rear panel Output impedance approx. 1 k Ω
Sweep Gate Signal Outputs	A sweep gate signal output: Approx. 5 Vp-p B sweep gate signal output: Approx. 5 Vp-p	BNC terminals at rear panel Output impedance approx. 1 k Ω

o Calibration Signal

Item	Specification	Remarks
Waveform	Positive pulse signal	
Frequency	1 kHz \pm 0.1%	
Output Voltage	0.5 Vp-p \pm 2%	
Output Resistance	Approx. 2 k Ω	

885649

o Pen Out Signals (COM7201E, COM7101E, COM7061A)

Item	Specification	Remarks
Output Signals for X-Y Recorder	Delivered when in storage mode	
X-axis output	0.1 V/DIV $\pm 10\%$ (Speed automatically varies in response to Y-axis amplitude.)	BNC terminal at rear panel (common with sweep signal output terminal)
Y-axis Output	0.1 V/DIV $\pm 10\%$	BNC terminal at rear panel
SYNC Output	TTL level (When in Pen Out: "HIGH")	BNC terminal at rear panel (common with A sweep gate terminal)

o CRT Circuit

Item	Specification	Remarks
Cathode-ray Tube	6-inch square screen, with internal white graticule Effective screen area: 8 x 10 cm (3.15 x 3.94 in.) Acceleration voltage: Approx. 20 kV	

o Power Requirements

Item	Specification	Remarks
Line Voltage	90 to 250 V	No voltage selection required.
Line Frequency	50/60 Hz	
Power consumption	COM7201E, COM7101E, COM7061A: Approx. 103 watts	
	COM7200A, COM7100A, COM7060A: Approx. 65 watts	

885650

- Memory Backup:
 - Data protected: Panel setting data, calibration data, waveform data, and RC01-COM setting data.
 - Backup battery: Lithium battery (life expectancy 10 years or more from shipment from factory, at 25°C (77°F))

- Probe power Supplies: For two active probes, through terminals at rear panel, for COM7201E and COM7200A

- Operation Environments: 0 to 50°C (32 to 122°F), 95% RH or less

- Environment for Performance to Specification: 5 to 45°C (41 to 113°F), 90% RH or less

- Mechanical Dimensions
 - Overall Sizes: 318 W × 150 H × 400 D mm (Mainframe)
(12.52 W × 5.91 H × 15.75 D in.)
 - 380 W × 200 H × 465 D mm (Maximum)
(14.96 W × 7.87 H × 18.31 D in.)

 - Weights COM7201E, COM7101E, COM7061A: Approx. 10 kg (22 lbs)
COM7200A, COM7100A, COM7060A: Approx. 8 kg (18 lbs)

- Accessories
 - Power code One

 - Instruction manual One

 - Probes COM7201E, COM7200A: Two P250-2 probes (10:1)
COM7101E, COM7100A: Two P100-S1 probes (10:1/1:1)
COM7061A, COM7060A: Two P060-S probes (10:1/1:1)

885651

3. PRECAUTIONS BEFORE OPERATING THE OSCILLOSCOPE

3.1 Unpacking the Oscilloscope

The oscilloscope is shipped from the factory after being fully inspected and tested. Upon receipt of the instrument, immediately unpack and inspect it for any damage which might have been sustained when in transportation. If any sign of damage is found, immediately notify the bearer and/or the dealer.

3.2 Environments

The normal ambient temperature range of this instrument is 0 to 50°C (32 to 122°F). Operation of the instrument outside of this temperature range may cause damage to the circuits.

Do not use the instrument in a place where strong magnetic or electric fields exist. Such fields may disturb the measurement.

3.3 CRT Intensity

In order to prevent permanent damage to the CRT phosphor, do not make the CRT trace excessively bright or leave the spot stationary for an unreasonably long time.

3.4 Maximum Safe Input Voltages

The maximum safe input voltages applicable to the input terminals and probes are as shown in the below table. Do not apply any voltages higher than these limits.

Input Terminals	Maximum Safe Input Voltage
CH1, CH2, CH3, CH4, (1 MΩ)	400 V peak (DC + AC peak)
CH1, CH2 (50 Ω)	5 V rms
Probes	600 V peak (DC + AC peak)
Z-axis	50 V peak (DC + AC peak)

885652

4. OPERATING

4.1 Description of Front Panel

This section gives descriptions of the front panel items referring to Figure 4-1.

*: Functions of the items indicated by the asterisk marks partially differ when in the storage mode. Refer to Section 4.2.

o CRT circuits.

POWER ① The main power switch of the oscilloscope. When power is turned on, the LED illuminates.

INTEN ② Controls brightness of the spot or trace. For approximately 1 second after this knob is pushed in, the beam finder function is brought into effect and the direction in which the beam has been deflected off and lost from the CRT screen can be identified.

TRACE ROTATION ③ Semi-fixed potentiometer for aligning the horizontal trace with graticule lines.

FOCUS ④ For focusing the trace to the sharpest image.

* B INT, SCAL, READOUT .. ⑤ Each time as you press this control, its function is switched over to B INT (B sweep intensity control), SCAL (graticule illumination control), or READOUT (CRT readout character brightness and cursor brightness control).

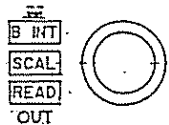

When in the A sweep mode, its function is switched over to SCAL or READOUT only.

Bezel ④ Acts as a base to install a camera.

Filter ④ Filter (grey) to improve contrast of waveform displayed on CRT. Readily removable.

885653

o Vertical Axes

- CH1 & X input ⑧ CH1 vertical axis input terminal. X-axis (horizontal direction) input terminal when in X-Y mode.
- CH2 input ⑫ CH2 vertical axis input terminal. Y-axis (vertical direction) input terminal when in X-Y mode.
- CH3 input ⑭ CH3 vertical axis input terminal. Y-axis (vertical direction) input terminal when in X-Y mode.
- CH4 input ⑯ CH4 vertical axis input terminal. Y-axis (vertical direction) input terminal when in X-Y mode.
- AC/DC, GND, 50Ω ⑨ ⑬ Switches to select coupling of input terminal to vertical amplifier of CH1 and CH2.
For COM7200A and COM7201E only
AC/DC: Each time as you strike this key, coupling mode is changed to AC or DC.

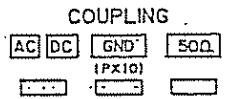

GND: Input of vertical amplifier is grounded and input terminal is made open.

50Ω: To select input impedance between 50Ω and 1MΩ. When 50Ω is selected, LED illuminates.

- AC, GND, DC ⑨ ⑬ Switches to select coupling of input terminal to vertical amplifier of CH1 and CH2.
For COM7101E, COM7100A, COM7061A and COM7060A only

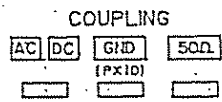

GND: Input of vertical amplifier is grounded and input terminal is made open.

DC: DC coupling

- AC/DC, GND, ÷5 ⑮ ⑰ Switches to select coupling of input terminal to vertical amplifier of CH3 and CH4.
AC/DC: Each time as you strike this key, coupling mode is changed to AC or DC.

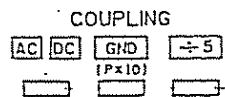

885654

GND: Input of vertical amplifier is grounded and input terminal is made open.

÷5: Each time as you strike this key, deflection factor is changed between 0.1 V/DIV and 0.5 V/DIV. When 0.5 V/DIV is selected, LED illuminates.

VOLTS/DIV ⑥ ⑩

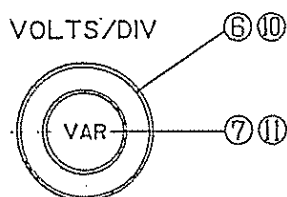

To select deflection factor of CH1 or CH2, from 1 mV/DIV to 5 V/DIV in 12 ranges. The selected range is digitally displayed on CRT.

VARIABLE ⑦ ⑪

Vernier adjustment of deflection factor of CH1 or CH2. Adjustment is down to 1/2.5 or less of the deflection factor indicated by VOLTS/DIV switch. When this knob is pushed in (calibrated position), deflection factor is as indicated by VOLTS/DIV switch. When this knob is pushed out (uncalibrated position), it acts as a vernier control.

* POSITION ③⑤ ③⑦ ③⑧ ④⑩

Vertical positioning of trace or spot. CH1 POSITION ④⑩ acts also as a horizontal positioning control when in X-Y mode. CH2 POSITION ③⑧ acts also as an INV switch and the polarity of the CH2 signal is inverted each time as you press this knob.

* VERT MODE ③⑨

To select vertical modes. You may strike CH1, ADD, CH2, CH3 and CH4 keys to select them in any combination. The LED lamps of the selected ones illuminate and the corresponding signals are displayed on CRT. As you strike keys again, the corresponding LED lamps and displayed signals go off, except when in single channel mode.

ADD: Algebraic sum or difference of CH1 and CH2 signals is displayed.

ALT/CHOP: Selects ALT mode or CHOP mode. When in ALT mode, channels are swept alternately with one complete sweep cycle for each channel. When in CHOP mode, channels are swept in turn being chopped at a frequency of approximately 1 MHz.

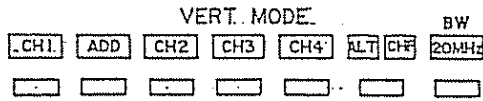

20MHz BW: Bandwidth of vertical amplifier is limited at approximately 20 MHz. This mode is used to cut off undesirable frequencies wider than 20 MHz and is selectable irrespective of settings of other switches.

o Time Base (Horizontal Axis)

A, B TIME/DIV ⑩ Selects sweep time of A sweep or B sweep (delayed sweep). The pushed-in position of the knob is for A sweep and the pulled-out position is for B sweep.

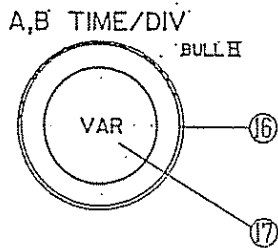

Even when the knob is in the pulled-out position, however, if HORIZ MODE ⑩ is set for A sweep, this switch is for A sweep.

Either when in A sweep or B sweep, sweep time is digitally displayed on CRT.

* VARIABLE ⑪ Vernier control of A sweep time, for up to 2.5 times or more slower than the speed selected by A TIME/DIV switch.

When the knob is set in the pushed-in position (calibrated position), sweep speed is as selected by A TIME/DIV switch. When the knob is set in the pulled-out position (uncalibrated or vernier position), sweep speed is continuously adjustable.

885656

* MODE ②③ Select sweep mode as below, and act also as a RESET switch when in the SINGL mode.

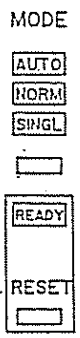

AUTO: When no triggering signal is applied or when triggering signal frequency is lower than 50 Hz, sweep runs automatically in a free mode.

NORM: When no triggering signal is applied, sweep is in a standby state and no trace is displayed on CRT. This mode is used primarily for viewing of signals of lower than 50 Hz.

SINGL: When a triggering signal is applied, the sweep runs one time. As you press the RESET switch after the sweep is over, the sweep circuit is rest to the READY state and the READY lamp illuminates. The READY lamp goes off when the sweep is over.

* HORIZ MODE ③④ Select X-Y mode, A sweep mode or B sweep mode, as follows.

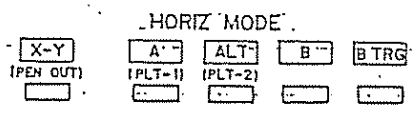

X-Y: For X-Y mode of operation with CH1 for X-axis and CH2, CH3, and/or CH4, for Y-axes. Y-axes are selectable with VERT MODE ③⑨. If no selection for Y-axes (CH2 - CH4) is made before selecting the X-Y mode, CH1 and CH2 are automatically selected for the X-Y mode of operation.

A: Selects A sweep alone for single time base mode of operation.

ALT: A sweep (regular sweep) and B sweep (delayed sweep) run alternately. A sweep is with accentuated brightness for the section to be magnified. B sweep is for display of the magnified waveform.

885657

B: Selects B sweep (continuously delayed sweep). Sweep speed is as selected by B TIME/DIV switch. Sweep starts when period preset by DELAY TIME POSITION ③③ has elapsed.

B TRIG: Selects triggered delay, and is enabled when in ALT or B sweep mode. B sweep starts as triggered by B trigger signal after delay time set by DELAY TIME POSITION ③③ has elapsed. When in the B TRIG mode, the AUTO LEVEL ②⑦, TRIG SLOPE ②⑧, and TRIG LEVEL ③⑩ are change to B trigger function and their green lamps illuminate as well as those of the TRIG SOURCE ②④ and TRIG CPLG ②⑤ to indicate that they are set for B triggering.

POSITION ②⑩

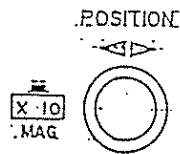

For horizontal positioning of the trace or spot. When in the x10 MAG mode, the horizontal position of the beam spot (trace) is adjustable for a range of approximately 20 DIV with the POSITION control. As you turn the control to the full clockwise or counterclockwise position (to the end position), the beam spot (sweep) moves automatically and continuously to the right or left, respectively. To stop the moving beam spot (trace), turn the control in the reverse direction from the end position.

885658

○ TRIGGERING

SOURCE ②④ Selects the triggering the signal source. Switch A selects the A triggering. Switch B selects the B triggering only when HORIZ MODE ③⑤ is set for the ALT mode or for the B sweep and the B TRIG mode.

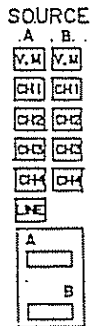

V-MODE: The input signal selected by (V.M) VERT MODE ③⑨ is used as the triggering source signal. When in a multi-channel mode, triggering is made in ALT mode, and V-MODE lamp and the indicator lamp of the selected channel illuminate.

When CHOP mode is selected by VERT MODE ③⑨ or when AUTO LEVEL ②⑦ is selected, however, the left most one alone of the indicator lamps of the selected channels illuminates indicating that the corresponding channel signal is selected for triggering source signal.

CH1: CH1 input signal is used as triggering source signal.

CH2: CH2 input signal is used as triggering source signal.

CH3: CH3 input signal is used as triggering source signal.

CH4: CH4 input signal is used as triggering source signal.

LINE: AC line signal is used as triggering source signal. The A TRIG mode alone is selectable.

Note: When in the A TRIG mode, an orange lamp illuminates; when in the B TRIG mode, a green lamp illuminates.

885659

CPLG 25

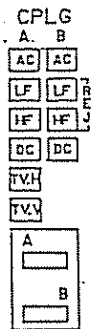

These switches select the coupling mode between the triggering signal source and the trigger circuit. Switch A selects the A triggering mode (the orange lamp illuminates) and switch B selects the B triggering mode (the green lamp illuminates). When in the A triggering, these switches also select the coupling to TV sync circuit. The B triggering can be selected only when the HORIZ MODE 36 is set for the B TRIG mode.

AC: AC coupling, eliminating DC components

LF-REJ: Components lower than 50 kHz are rejected.

HF-REJ: Components higher than 50 kHz are rejected.

DC: DC coupling

TV.H: Triggering is made with TV horizontal sync signal. Effective for A TRIG mode only.

TV.V: Triggering is made with TV vertical sync signal. Effective for A TRIG mode only.

SLOPE 28



Selects either positive-going slope or negative-going slope for triggering point.

+: Triggering occurs when a positive-going signal crosses the trigger level.

-: Triggering occurs when a negative-going signal crosses the trigger level.

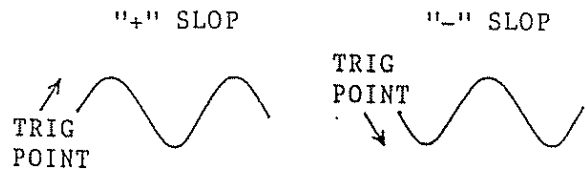

NOTE: When in the A TRIG mode, an orange lamp illuminates; when in the B TRIG mode, a green lamp illuminates.

885660

LEVEL ③⑩ Controls the triggering level to adjust the starting point of the waveform displayed on CRT.

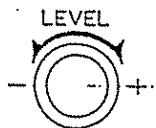

When A/B TRIG selector switch ②⑥ is set for A TRIG, this knob is used to adjust the A TRIG level; When set for B TRIG, this knob is used to adjust the B TRIG level.

When in the A TRIG mode, TRIG LED ②⑨ illuminates.

LEVEL AUTO ②⑦ When in the LEVEL AUTO mode, the LEVEL control ③⑩ is disabled and the triggering level is maintained at an optimal level covering from the minimum amplitude to the maximum amplitude.

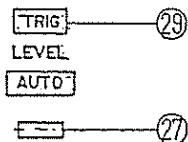

Note: When in the A TRIG mode, the orange lamp illuminates; When in the B TRIG mode, the green lamp illuminates.

A/B ②⑥ Selects either the A or the B triggering mode for the SLOPE ②⑧, LEVEL ③⑩, and LEVEL AUTO ②⑦ which are used in common for both the A and the B triggering. Each time as you press this switch, either the A or the B triggering mode is selected.

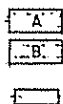

This switch is effective only when the HORIZ MODE ③⑥ is set for the ALT mode or for the B sweep and the B TRIG mode.

Immediately after the HORIZ MODE ③⑥ is set for the ALT mode or for the B sweep and the B TRIG mode, the B indicator lamp illuminates and the above common-use controls are set for the B triggering.

Unless the HORIZ MODE ③⑥ is set for the B TRIG mode, the A/B switch does not operate, the A lamp illuminates, and the above mentioned common-use controls are in the A triggering mode.

885661

o CRT Readout

The functions of the CURSOR SW ③① and the SUB CURSOR SW ③② for data to be displayed on the CRT readout can be set mutually independently for each of the A, ALT, and the B sweep modes which are selectable with the HORIZ MODE ③⑥. For example, you may set the CURSOR SW ③① for the $1/\Delta T$ measuring function for the ALT sweep mode and for the ΔT measuring function for the B sweep mode. With this setting, simply by selecting the HORIZ MODE ③① thereafter, measurement will automatically become OFF when in the A sweep mode, frequency ($1/\Delta T$) measurement when in the ALT sweep mode, or period (ΔT) measurement when in the B sweep mode. The above, however, is not applicable to other cursor functions. The functions of the switches related to the CRT readout for respective settings of the HORIZ MODE ③⑥ are described in this section.

(1) When HORIZ MODE ③⑥ is set for A sweep

CURSOR SW ③①

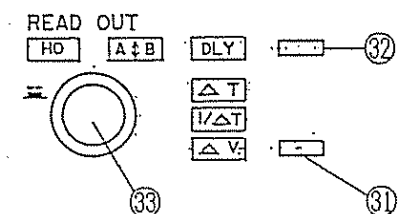

This switch selects three functions. Measurement ΔT , $1/\Delta T$ or ΔV cursor and measurement off. As this switch is changed, functions of the READOUT control ③③ are changed automatically. (When in the measurement OFF state, the HO lamp illuminates to indicate that the READOUT control ③③ is acting as a HOLD-OFF control.)

When in any one of the above types of measurement, position of the dotted-line cursor is adjustable with the READOUT control ③③. The adjustable range is approximately ± 1 DIV from center of screen. As you turn the control to the full clockwise or counterclockwise position (to the end position), the cursor moves automatically and continuously. To stop the moving cursor, turn the control in the reverse direction from the end position.

The cursor line can be changed to broken lines or to dotted lines by pressing the knob.

When both cursor lines are dotted, they are in the tracking mode and can be moved keeping the distance between them constant.

885662

Each time as you press the knob, the cursor changes in the order of broken line → tracking mode → dotted line tracking mode → broken line.

ΔT : Differential time between two vertical cursors (one is broken line and the other is dotted or broken line) is determined and digitally displayed on CRT.

When SWEEP VARIABLE ⑰ is set in the on state, time ratio with reference to 5 DIV as 100% is determined and displayed. This mode of operation is convenient for measurement of the duty ratio of pulse wave.

$1/\Delta T$: Differential time between two vertical cursors (one with broken line and the other with dotted or broken line) is determined and its reciprocal is calculated and digitally displayed as frequency.

When SWEEP VARIABLE ⑰ is set in the abled state, phase with reference to 5 DIV as 360 degrees is determined and displayed.

This mode of operation is convenient for measurement of phase difference.

ΔV : Differential voltage between two horizontal cursors (one with broken line and the other with dotted or broken line) is determined and digitally displayed on CRT.

Scale factor is as that of CH1, except when CH2 single channel is selected by VERT MODE ⑳ in which case scale factor is as that of CH2.

885663

When the VARIABLE knob is in the pushed out state (UNCAL state), voltage ratio with reference to 5 DIV as 100% is determined and displayed.

* SUB CURSOR SW ⑳ This switch changes READOUT control ㉓ to holdoff control function when in ΔT , $1/\Delta T$, or ΔV measurement.

As you press this switch, HO: lamp illuminates and holdoff period becomes adjustable. As you press this switch again or press the READOUT control ㉓, HO lamp goes off and cursor measurement resumes.

When the ΔT , $1/\Delta T$ and ΔV are not selected the HO lamp, constantly illuminates and the READOUT control ㉓ adjusts the holdoff function and the SUB CURSOR SW ㉒ is disabled.

When in A sweep mode		Function selectable with SUB CURSOR SW	
Function selectable with CURSOR SW ㉒	LED lamp Indication	ΔT	ΔT , HO
	Control function	Cursor position	Holdoff time
	LED lamp indication	$1/\Delta T$	$1/\Delta T$, HO
	Control function	Cursor position	Holdoff time
	LED lamp indication	ΔV	ΔV , HO
	Control function	Cursor position	Holdoff time
	LED lamp indication	HO	_____
	Control function	Holdoff time	_____

885664

(2) When HORIZ MODE ③⑥ is set for ALT sweep

* CURSOR SW ③① This switch selects the functions of the READOUT control ③③ for delay time setting or time interval measurement (ΔT , $1/\Delta T$) with delayed sweep.

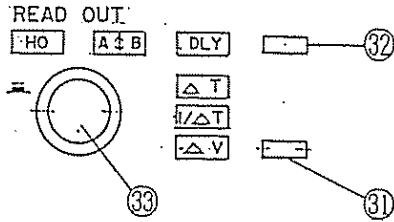

When in the ΔT or $1/\Delta T$ measuring mode, controllable intensity modulation sections can be changed by pressing the READOUT control ③③.

When in the tracking mode, as in the case of measurement with cursors, two intensity-modulated sections can be moved keeping the distance between them constant.

Each time as you press the control knob, control function changes in the order of intensity modulation A \rightarrow tracking mode \rightarrow intensity modulation B \rightarrow tracking mode \rightarrow intensity modulation A.

DLY: READOUT control ③③ acts as delay time control for B sweep. The delay time is digitally displayed on CRT.

When SWEEP VARIABLE ①⑦ is set in the on state, delay time displayed on the CRT is in the unit of DIV.

ΔT : Differential time between two intensity-modulated sections on A sweep is determined and digitally displayed on CRT.

When in single channel mode, two intensity-modulated sections are displayed on the same trace.

885665

When in multi-channel mode and VERT MODE (39) is set for ALT mode but TRIG SOURCE (29) is not set for V-MODE triggering, intensity-modulated sections are displayed on channels with priority in the order of CH1, CH2, CH3, CH4, and ADD, with one intensity modulated section on the trace of an odd number channel and the other intensity modulated section on the trace of an even number channel, for measurement of differential time between channels.

When an odd number of channels are measured, however, two intensity-modulated sections are displayed on the trace of the lowest-priority channel. When in the five-trace mode (CH1, CH2, CH3, CH4, and ADD), one intensity-modulated section is displayed on CH1 trace and the other intensity-modulated section on CH2 trace, while both intensity-modulated sections are displayed on each of CH3, CH4, and ADD traces.

When SWEEP VARIABLE (17) is set in the on state, time ratio with reference to 5 DIV as 100% is determined and displayed.

1/ΔT: Differential time (period) between intensity-modulated sections on A sweep is determined and its reciprocal (frequency) is calculated and displayed.

When the SWEEP VARIABLE (17) is set in the on state, phase difference is measured and displayed with a reference of 5 DIV as 360 degrees.

885666

* SUB CURSOR SW ⑳ This switch selects the function of READOUT control ㉓ between holdoff function when in DLY, ΔT or $1/\Delta T$ mode and trace separation function.

As you press this switch, HO lamp illuminates and holdoff time becomes adjustable. As you press this switch again, A \updownarrow B lamp illuminates and B sweep position with respect to A sweep position is vertically adjustable when in ALT mode. As you press this switch once more, DLY, ΔT or $1/\Delta T$ measurement resumes. It resumes also as you press the READOUT control ㉓.

When in ALT mode		Function selectable with SUB CURSOR SW ㉓		
Function selectable with CURSOR SW ㉓	LED lamp indication	DLY	DLY, HO	DLY, A \updownarrow B
	Control function	Delay time	Holdoff time	Trace separation
	LED lamp indication	ΔT	ΔT , HO	ΔT , A \updownarrow B
	Control function	Intensity modulation section positioning	Holdoff time	Trace separation
	LED lamp indication	$1/\Delta T$	$1/\Delta T$, HO	$1/\Delta T$, A \updownarrow B
	Control function	Intensity modulation section positioning	Holdoff time	Trace separation

(3) When HORIZ MODE ③⑥ is set for B sweep

* CURSOR SW ③① This switch selects the functions of the READOUT control ③③ for delay time setting or time interval measurement (ΔT , $1/\Delta T$) with delayed sweep.

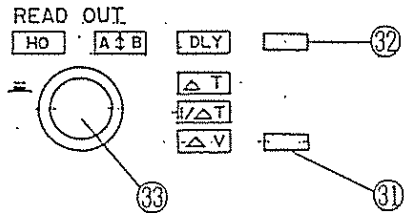

When in ΔT or $1/\Delta T$ measuring mode, controllable B sweep can be changed by pressing the READOUT control ③③.

Each time as you press this knob, the control function changes in the order of B sweep a \rightarrow tracking mode \rightarrow B sweep b \rightarrow tracking mode \rightarrow B sweep a.

DLY: Delayed and magnified sweep is displayed on CRT, with delay time controllable with the READOUT control ③③. Delayed time is digitally displayed on CRT.

When SWEEP VARIABLE ①⑦ is set in the on state, delay time is displayed in the unit of DIV.

ΔT : Differential time between two B sweeps is determined and digitally displayed on the CRT.

When in single channel mode or CHOP mode, differential time between two points on the same signal waveform is displayed.

When in multi-channel mode and the VERT MODE ③③ is set for ALT mode but TRIG SOURCE ②④ is not set for V-MODE triggering, it measures the period of time between one point on the trace of the odd-number channel and the

885668

other point on the trace of the even-number channel, with channel priority in the order of CH1, CH2, CH3, CH4, and ADD. When an odd number of channels are displayed, differential time between two points on the same trace is measured for the channel of the lowest priority. Except when in the 5-trace mode with CH1, CH2, CH3, CH4 and ADD, differential time between CH1 and CH2 and that between two points on each of the remaining traces are displayed.

When in triggered delay mode, a sign of inequality on CRT is affixed to prevent reading errors.

When SWEEP VARIABLE ⑰ is set in the on state, time ratio with reference to 5 DIV on A sweep as 100% is measured and displayed.

1/ΔT: Differential time (period) between two points on B sweep is determined and its reciprocal (frequency) is calculated and displayed.

When SWEEP VARIABLE ⑰ is set in the on state, phase difference with reference to 5 DIV on A sweep as 100% is measured and displayed.

885669

* SUB CURSOR SW ⑳ This switch selects function of READOUT control ㉓ between holdoff function and trace separation function when in DLY, ΔT or $1/\Delta T$ mode.

When trace separation function is selected, all traces displayed on CRT are of B sweep mode. The trace which is movable with the knob is of the lowest priority channel.

To return to DLY, ΔT or $1/\Delta T$ mode, press again this switch or press the READOUT control ㉓.

When in B sweep mode		Function selectable with SUB CURSOR SW ㉓		
Function selectable with CURSOR SW ㉑	LED lamp indication	DLY	DLY, HO	_____
	Control function	Delay time	Holdoff time	_____
	LED lamp indication	ΔT	ΔT , HO	ΔT , A \updownarrow B
	Control function	Intensity-modulated position adjustment	Holdoff time	Trace separation
	LED lamp indication	$1/\Delta T$	$1/\Delta T$, HO	$1/\Delta T$, A \updownarrow B
	Control function	Intensity-modulated position adjustment	Holdoff time	Trace separation

(4) Digital voltmeter and frequency counter functions

* DVM SW ③ This switch selects the DVM function to measure the AC, DC, or peak-to-peak voltage of the signal applied to CH1 input.

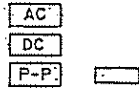

The measured value is digitally displayed on CRT.

When the DVM is set in the on state, frequency of the triggering source signal selected by TRIG SOURCE ④ also is measured in an auto-range system and displayed on CRT. DVM and counter are disabled when COM7201E, COM7101E, or COM7061A is in storage mode.

Each time as you press the switch, measurement is changed in the sequence of AC voltage, DC voltage, peak-to-peak voltage, and off.

Note: Note that measurement by DVM may involve larger errors when the measured signal amplitude is unreasonably small or large.

Note also that frequency counter may not operate when the signal pulse width is very narrow, the signal amplitude is very small, or when the signal is in a state such that no triggering is successfully effected.

AC: Measures the AC voltage (true rms value) of the signal applied to CH1 input for a range of 20 Hz - 100 kHz.

885673

When COUPLING ⑨ of CH1 is set to AC-coupling, rms value of AC voltage signal is measured; when it is set to DC-coupling, DC + AC rms value is measured.

DC: Measures the DC voltage of the signal applied to CH1 input.

p-p: Measures the peak-to-peak voltage of the signal applied to CH1 input, for a frequency range of 20 Hz - 10 MHz.

Symbols displayed on CRT are as shown in the following table.

DVM SW ⑭	CH1 COUPLING ⑨	Symbol
AC	AC	V
	DC	V
DC	AC	? V
	DC	V
P-P	AC, DC	p...V

o Others

CAL (Vp-p) ⑳ This terminal provides a 1 kHz $\pm 0.1\%$ squarewave 0.5 Vp-p calibration signal with $\pm 2\%$ voltage accuracy. Output resistance is approximately 2k ohms.



..... ㉑ Ground terminal



4.2 Description of Front Panel (for Storage Mode)

This section gives descriptions of the front panel items for the storage mode of COM7201E, COM7101E, and COM7061A, referring to Figure 4-2.

For other front panel items, see Section 4.1.

o CRT Circuits

- B INT, SCAL, READOUT .. ⑤ Each time as you press this knob, its function is changed to SCAL (adjustment of graticule illumination brightness) or READOUT (adjustment of readout character and cursor brightness). When in the storage mode, this knob is not changed to B INT.

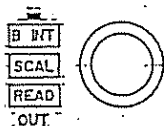

o Vertical Axes

- POSITION ③⑤ ③⑦ ③⑧ ④⑩ Vertical positioning of trace.
On even when in PAUSE state.

- VERT MODE ③⑨ Select vertical axes. Any combination of CH1, CH2, CH3, and CH4 can be selected.

When in single channel mode or ALT mode, the lamps of the selected channels illuminate. For CHOP mode, CH1 and CH2 alone are selectable.

As you press again the switch, the lamp goes off except when in the single channel mode.

The ADD function cannot be used.

ALT, CHOP: Selects ALT or CHOP mode for multi-channel operation.

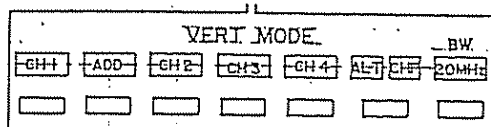

When in ALT mode, the signals are acquired alternately for the selected channels. When TRIG SOURCE ②④ is set for V-MODE, triggering is made in ALT mode.

885673

When in CHOP mode, CH1 and CH2 signals are acquired simultaneously.

20MHz BW: Limits the bandwidth of approximately 20 MHz on vertical amplifier. This switch operates independent of other switches.

o Time Base (Horizontal Axis)

VARIABLE ⑰ This control remains disabled when in storage mode. Time base is as set by A or B TIME/DIV ⑱ irrespective of setting of this control.

MODE ⑲ Selects sweep mode. Sweep operation differs between the standard sweep mode and the ROLL mode which is selected when the sweep speed is 0.1 s/DIV or slower.



When the standard mode

AUTO: When no triggering signal is applied or triggering signal frequency is lower than 50 Hz, sweep runs automatically in a free run mode.

NORM: When no triggering signal is applied or no triggering is effected, the waveform of the current sweep cycle is kept displayed and the sweep circuit is in the standby state for the next trigger signal.

SINGL: When a triggering signal is applied, sweep runs only for one sweep cycle. When the sweep cycle is over, the READY lamp goes off and the data acquisition function pauses. As you press the RESET switch, the sweep circuit is reset to the READY state (the READY lamp illuminates) and the data acquisition function resumes. The VIEM TIME ⑳ remains in the disabled state.

885674

When in the ROLL mode

AUTO: The Sweep runs automatically in a free run mode, irrespective of triggering signal. Displayed waveform can be made stationary by PAUSE ④④.

NORM: When the VIEW TIME is OFF:
Sweep runs in a free run mode irrespective of triggering signal.

When the VIEW TIME is ON:
Sweep runs in a free run mode until triggering is effected. When triggering is effected, waveform becomes stationary at the point set by the TRIG POINT ④⑧ and remains in this state for the period set by the VIEW TIME ④⑦. When the period has elapsed, the ROLL operation will resume. However, the period for the subsequent 10 DIV's is a holdoff period during which the triggering signal remains ineffective. The triggering signal becomes effective after this period has elapsed. During the hold-off period, TRIG LED ②⑨ does not illuminate irrespective of the triggering signal.

SINGL: Sweep runs in a free run mode until triggering is effected. When triggering is effected, displayed waveform becomes stationary at the point set by the TRIG POINT ④⑧. When the 10-DIV hold-off period (during which triggering disabled and waveform is displayed in the ROLL mode) has elapsed after you have pressed the RESET switch, the READY lamp illuminates to indicate that triggering is enabled. When triggering is effected, the TRIG lamp ②⑨ illuminates, which as well as the READY lamp goes off when a single cycle of sweep is over.

885675

HORIZ MODE ③⑥ Select A sweep mode or delayed B sweep mode as described below. The X-Y switch remains disabled.

A: A sweep mode for general waveform viewing.

ALT: This mode is to select on A sweep a section of waveform (the section to be magnified on B sweep).

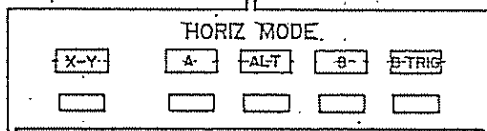

Symbol ^{DLY} is displayed above the A sweep waveform to indicate the starting point of magnification. In this case, TRIG POINT automatically becomes 0 DIV.

B: This mode is for continuous delayed sweep operation. Each sweep cycle starts after a period set by B TIME/DIV switch and DELAY TIME POSITION control (READOUT control ③③) has elapsed. The triggering point is displayed at the left end position (0 DIV position on the graticule).

B TRIG: This switch selects the triggered delay mode. This switch is effective when in ALT or B sweep mode.

B sweep is triggered by B triggering signal when the period set by DELAY TIME POSITION has elapsed.

When this switch is pressed, the AUTO LEVEL ②⑦, TRIG SLOPE ②⑧ and TRIG LEVEL ③⑩ are changed to the B triggering function and the green lamps illuminate to indicate the set status. Of the TRIG SOURCE ②④ and TRIG CPLG ②⑤ also, the green lamps illuminate indicating that they are set for the B triggering function and switch B can be operated.

885676

o CRT Readout

When in the storage mode, the CURSOR SW ③① is enabled provided that the HORIZ MODE ③⑤ is set for the A sweep mode--it is disabled if the HORIZ MODE ③⑥ is set for the ALT or B sweep mode. When you need the DVM function, select the real mode.

CURSOR SW ③① Selects ΔT , $1/\Delta T$ or ΔV measurement with cursors or measurement off when HORIZ MODE ③⑤ is set for A sweep mode. As you press this switch, function of READOUT control ③③ also is changed.

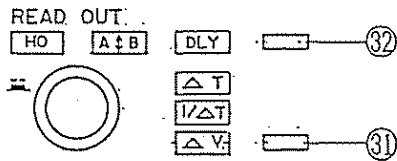

When measuring of any one of the above items, position of the dotted-line cursor is adjustable with READOUT control ③③. The adjustable range is approximately ± 1 DIV from mid-position setting of the control Knob. As you turn the control to the full clockwise or counterclockwise position (to the end position), the cursor moves automatically and continuously. To stop the moving cursor, turn the control in the reverse direction from the end position.

Cursor can be change between that of broken line and dotted line by pressing the knob. When both cursors are of dotted lines, they can be moved on CRT keeping the distance between them constant. Each time as you press the knob, cursor changes in the sequence of broken line \rightarrow tracking mode \rightarrow dotted line \rightarrow tracking mode \rightarrow broken line.

ΔT : Differential time between two vertical cursors (one with broken line and the other with dotted or broken line) is measured and digitally displayed on CRT.

$1/\Delta T$: Differential time (period) between two vertical cursors (one with broken line and the other with dotted or broken line) is determined and its reciprocal (frequency) is calculated and displayed on CRT.

885677

ΔV : Differential voltage between two horizontal cursors (one with broken line and the other with dotted or broken line) is measured and digitally display on CRT.

Note: Scale factor is as that of CH1, except when CH2 single channel mode is selected by VERT MODE ③⑨ in which case scale factor is as that of CH2.

SUB CURSOR SW ③② This switch remains disabled regardless of whether HORIZ MODE ③⑥ is set for A, ALT, or B sweep mode. HOLDOFF control is disabled when in storage mode.

DVM SW ③④ Disabled when in storage mode.

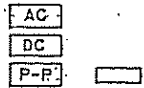

o Storage Circuit

MODE ⑤① Selects real mode or storage mode. When in storage mode, STRG lamp illuminates.

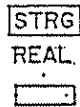

RESPONSE ⑤⑩ This switch selects either sine interpolation or pulse interpolation. This switch is enabled when time base is magnified after PAUSE mode or when SINGLE SWEEP operation is used at ranges higher than the maximum sampling rate (2 μ s/DIV and higher ranges).

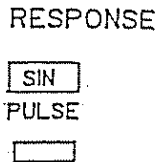

SINE lamp illuminates when in sine interpolation for sine wave. Almost full sine waveform interpolation can be successfully done when the number of the sampled data items per cycle is 2.5 or more.

885678

When in pulse interpolation, SINE lamp does not illuminate and the points representing the sampled data values are connected with straight lines. Pulse interpolation is especially effective for interpolation of pulse waves, although it allows almost full sine waveform interpolation for sine waves also when the number of the sampled data items per cycle is 10 or more.

ENV ④⑨ Selects the envelope mode, which displays the maximum and minimum values between sampling points.

ENV

The envelope mode allows you to identify narrow pulses which may exist between sampling clock pulses and detect aliasing when input signal frequency is higher than one half of the sampling frequency.

This switch is enabled when range setting is 50 ms/DIV to 10 μ s/DIV and ENV lamp illuminates.

When in the envelope mode, the waveform which is in the PAUSE state cannot be displayed with magnification.

TRIG POINT ④⑧ This switch selects a pretriggering point when in regular sweep mode or a sweep start point after pause for sweep magnification.

TRIG
POINT

The pretriggering point changes in the sequence of 0 DIV, 2 DIV, 4 DIV, 6 DIV and 8 DIV as you press this switch. Thus, this switch allows you to view waveform which existed before triggering. When in this mode, symbol $\overset{\text{TRIG}}{\downarrow}$ is displayed on CRT.

As you press PAUSE ④④, acquiring of new waveform ceases and symbol $\overset{\text{MAG}}{\downarrow}$ is displayed instead of $\overset{\text{TRIG}}{\downarrow}$, indicating that the starting point for sweep magnification is selectable with this switch. Each time as you press this switch, the point moves in 1-DIV step. Up to 11 points are selectable.

885679

When in the above state, sweep can be magnified up to 100 times by turning A.B TIME/DIV ⑩ to right and left from the position indicated by symbol $\begin{matrix} \text{MAG} \\ \downarrow \end{matrix}$.

VIEWTIME ④⑦ Selects a period during which same waveform is kept displayed on CRT, for approximately 1 sec, 3 sec, 10 sec, and off (continuous viewing of displayed waveforms).

VIEW
TIME



View time is indicated on CRT with a triangular symbol as follows.

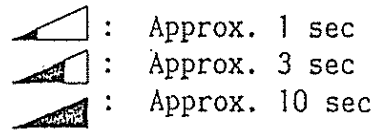

This switch is disabled when in REPERT mode or SINGLE SWEEP mode.

REF MEMORY ④⑤ Select reference memory units for saving of data of up to 4 waveforms.

SAVE ④⑤ Data is saved as you press PAUSE ④④ to halt acquiring of data, press REF MEMORY ④⑤ to select a memory unit or units in which data is to be stored, and then press SAVE ④⑤.

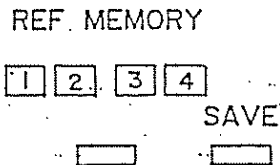

The memory units which are selectable by pressing REF MEMORY ④⑤ are as follows.

When in single channel mode:

Any one of memory units 1 - 4 can be selected.

When in 2-channel mode:

Combination of memory units 1 and 2 or memory units 3 and 4 can be selected. The left most selected channel of the VERT MODE ③⑨ is assigned to an odd-number memory unit.

885680

When in 3-channel mode:

The channels selected by VERT MODE ③⑨ are assigned to the corresponding numbers of memory units.

When in 4-channel mode:

The four channels are assigned to the four corresponding numbers of memory units.

PAUSE ④④



The current waveform is kept displayed continuously, halting acquisition and display of a new waveform. As you press the switch again, the halted state is released.

Transfer of data into reference memory and sweep magnification up to 100 times are enabled only when in the PAUSE mode. (See Section 5.1 (9) PAUSE.)

LOCAL SW ④③
(2nd FUNCTION KEY)

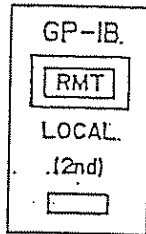

Selects either the remote control mode with GP-IB or the local control mode with panel switches. When in the remote control mode, the RMT lamp illuminates.

This switch acts also as a second function key. If you press the switch together with X-Y of HORIZE MODE ③⑥, contents of reference memory are delivered via X-Y recorder output terminal on rear panel. If you press the switch together with GND of COUPLING ⑨ ⑬ ⑮ ⑰, the vertical scale factor is changed for direct use with 10:1 probes. If you press the switch together with CURSOR SW ③①, the calibration verification mode for vertical and horizontal axes is effected. If you press the switch together with SUB CURSOR SW ③②, the system reset mode to reset the system when it has become abnormal is effected.

885681

4.3 Description of Rear Panel

This section gives descriptions of the rear panel items, referring to Figure 4-3.

CH1 OUT ⑤② Delivers CH1 output signal of approximately 50 mV/DIV. When 50-ohm terminated, output voltage is approximately 25 mV/DIV.

Z AXIS IN ⑤③ Accepts an external intensity modulation signal. Trace becomes dim with positive-going signal. Clearly discernible intensity modulation is effected with 3 Vp-p signal.

B GATE ⑤④ Delivers positive TTL-level gate signal corresponding to B sweep.

A GATE/SYNC OUT ⑤⑤ Delivers positive TTL-level gate signal corresponding to A sweep.

When PEN output signal is delivered in storage mode of COM7201E, COM7101E or COM7061A, positive TTL-level sync output signal corresponding to PEN output signal is delivered.

A SWEEP/PEN X OUT ⑤⑥ Delivers A sweep output signal of 0 to approximately +1 V. When in storage PEN output mode of COM7201E, COM7101E or COM7061A this terminal delivers X-axis output of 0 to approximately +1 V.

PEN Y OUT ⑤⑦ Delivers Y-axis output of 0 to approximately ± 0.5 V when in storage PEN output mode.
For COM7201E, COM7101E,
and COM7061A only

885682

- Power Connector and Fuse ⑤⑧ AC line power connector which act also as fuse holder.
- To replace the fuse, disconnect the power cord and then pry the nail of the fuse with a screwdriver.
- Studs (Cord Takeups) ⑤⑨ Act as studs and also as cord takeups.
- GP-IB Connector ⑥② Connector which complies with IEEE- 488-1978 GP-IB Standards.
For COM7201E, COM7101E and COM7061A only
- GP-IB Switches ⑥③ For setting of talk address (MTA) for response by interface and control of TALK ONLY (TON) local messages.
For COM7201E, COM7101E and COM7061A only
- REMOTE Connector ⑥④ For connection to Remote Controller RC01-COM or Probe Selector PS01-COM. For the RC01-COM and PS01-COM, refer to respective instruction manuals.
For COM7201E, COM7101E and COM7061A only
- PROBE POWER ⑥① Provide power for active probes
For COM7201E and COM7200A
- Fan ⑤⑩ Cooling fan air outlet

Note: Pay attention so that air flow from the outlet is not impeded.

885683

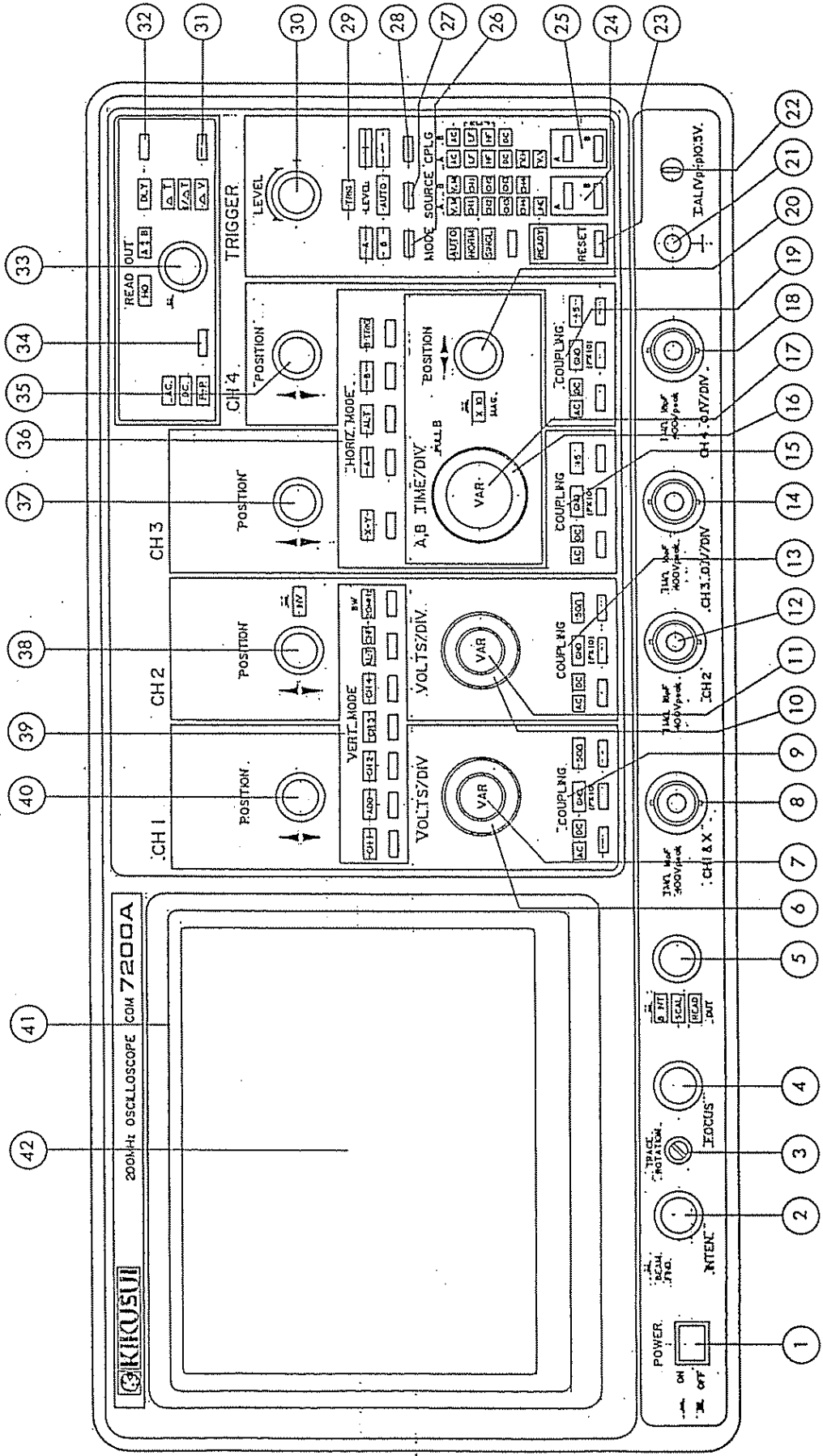

Figure 4.1. Front Panel of COM7200A

989988

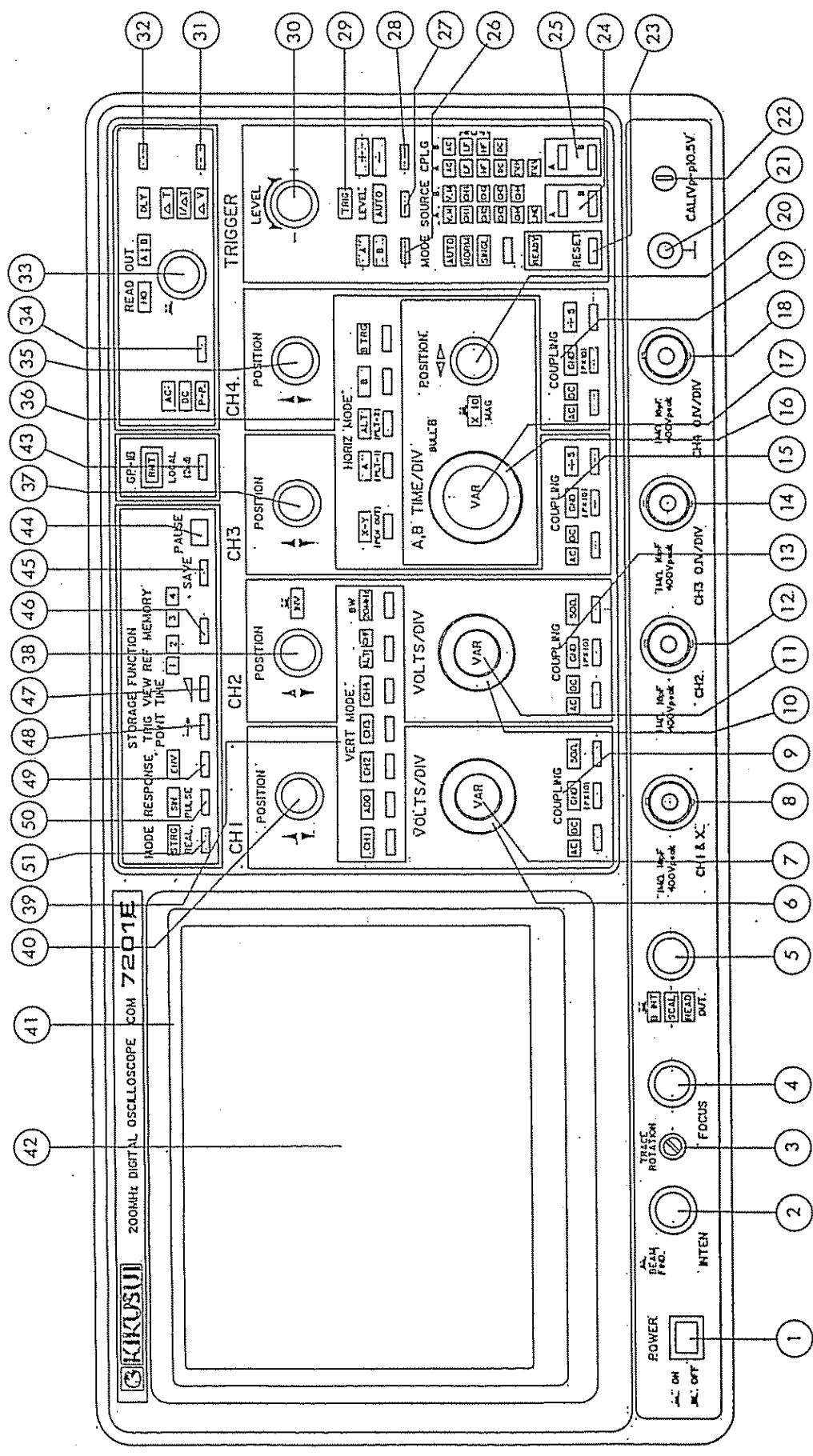

Figure 4-2. Front Panel of COM7201E

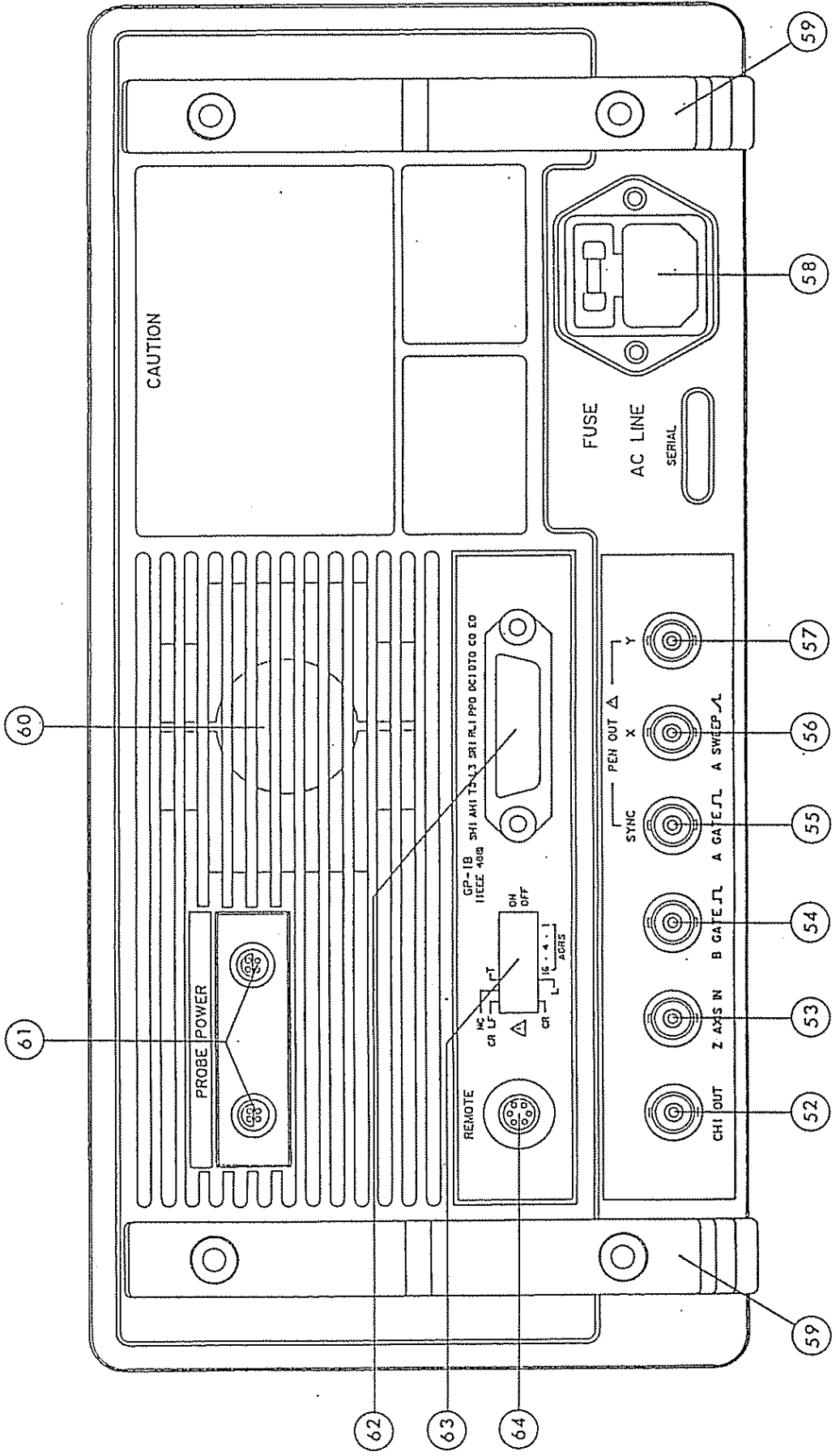
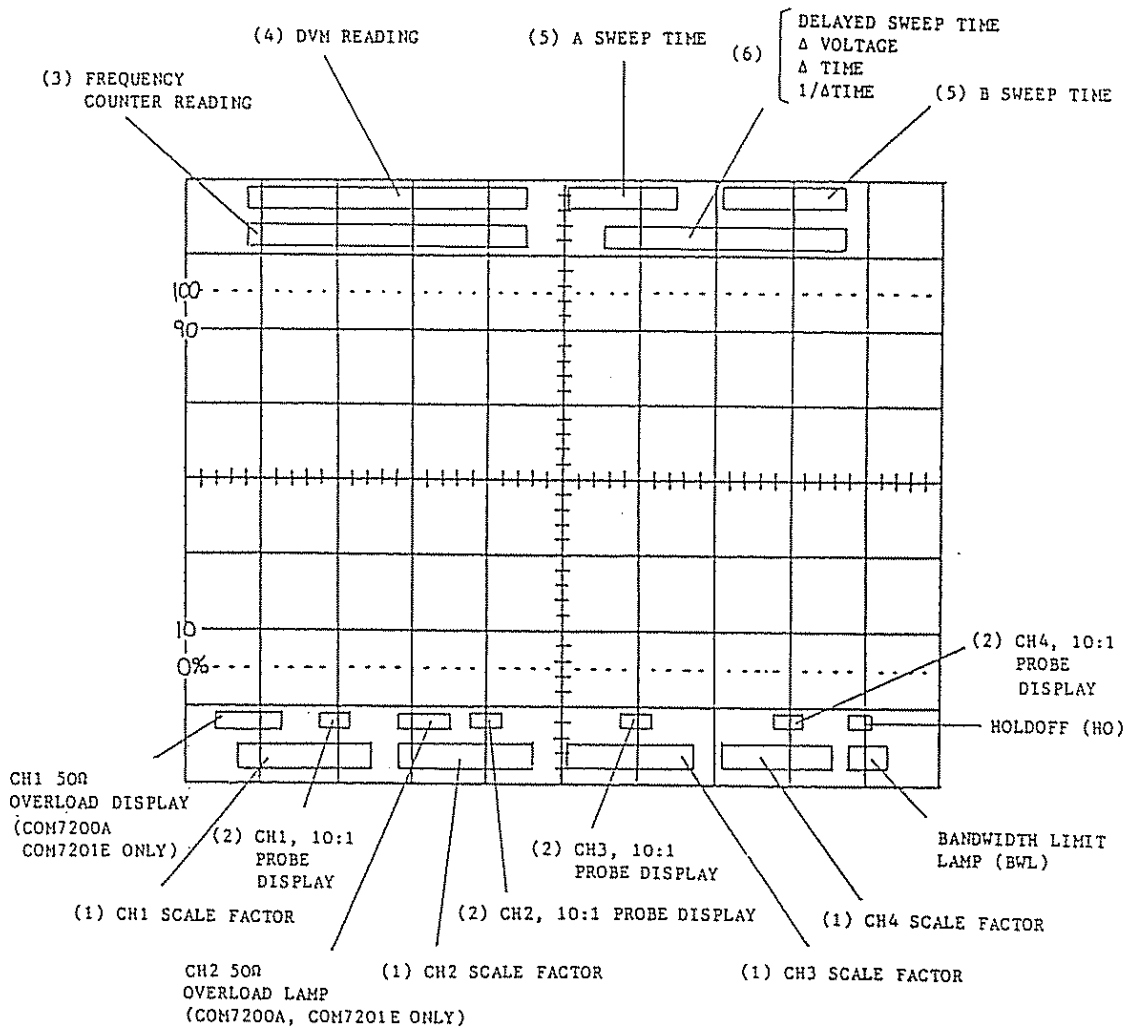

Figure 4-3. Rear Panel

4.4 Description of CRT Readout

- o This section explains the CRT readout of COM7201E, COM7101E and COM7061A when in the real mode and that of COM7200A, COM7100A and COM7060A.



(1) CH1 - CH4 scale factor

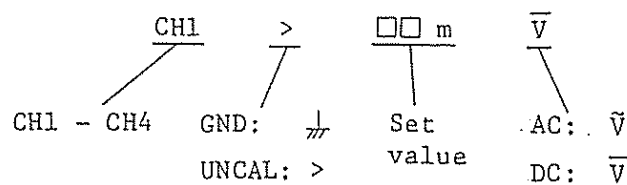

885687

(2) 10 : 1 probe display: $P \times 10$

(3) Frequency counter reading

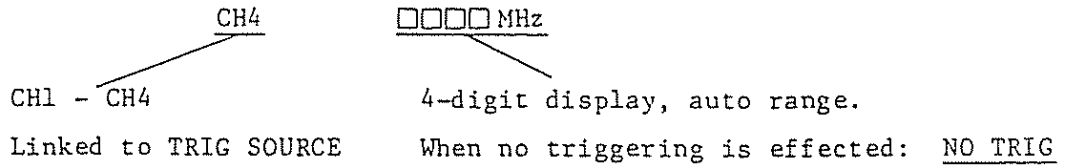

(4) DVM reading

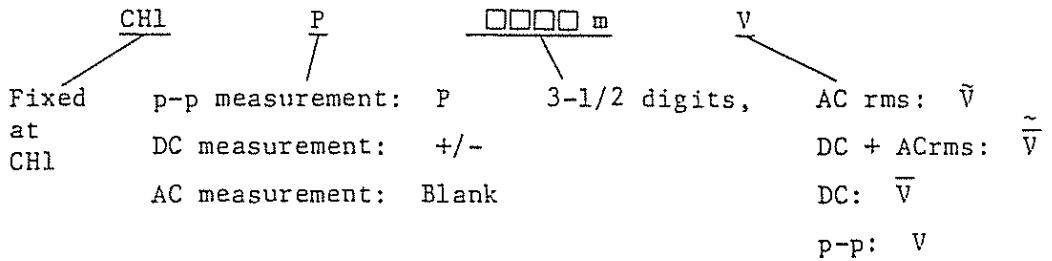

(5) A/B sweep time

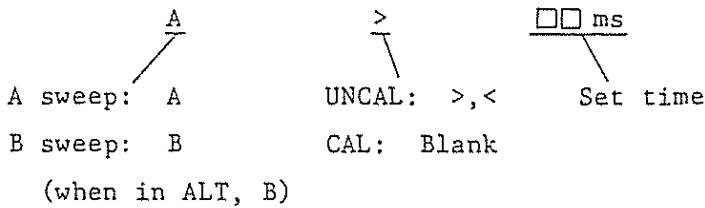

(6) Delayed sweep time

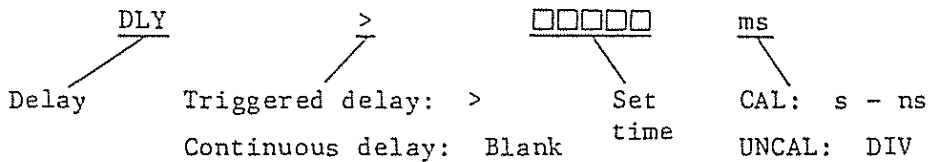

(6) ΔT measurement

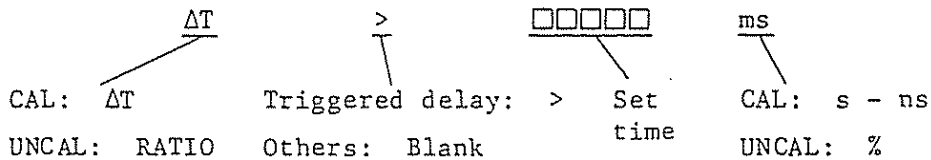

885688

- o This section explains the CRT readout of COM7201E, COM7101E and COM7061A when in the storage mode.

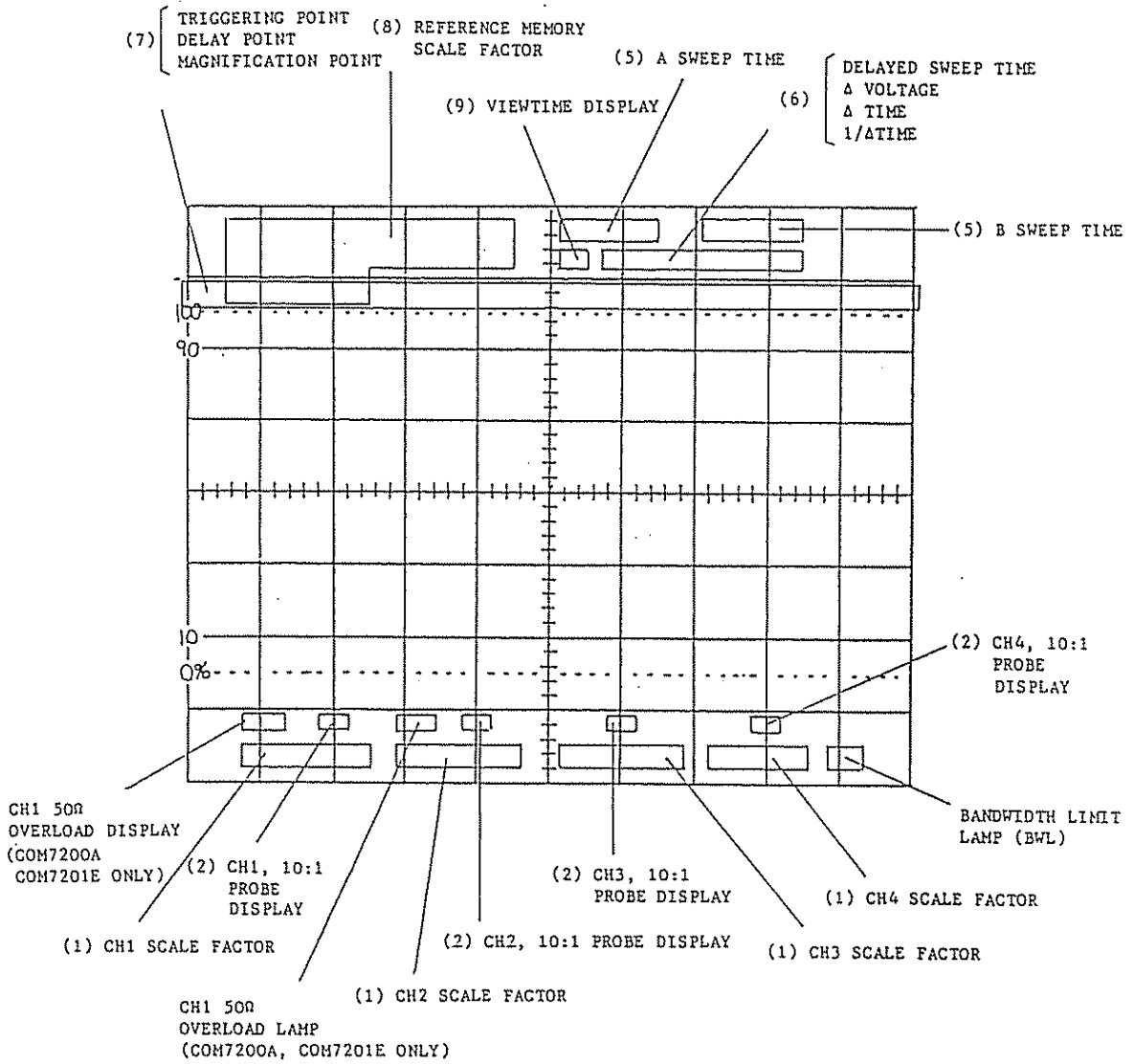

885690

(7) Triggering point, delay point and magnification point

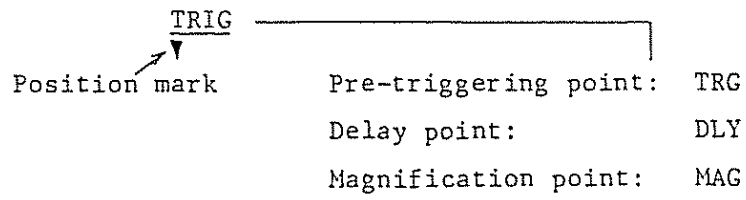

(8) Reference memory scale factor

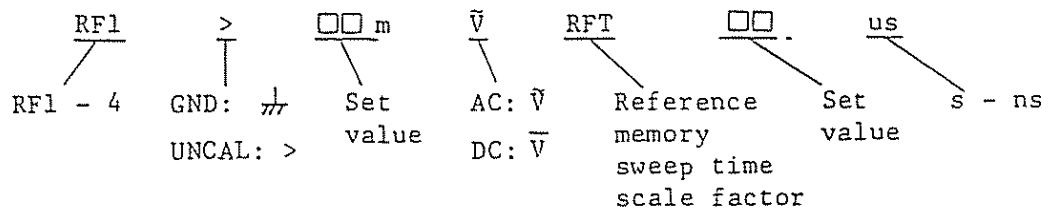

(9) Viewtime display

- Continuous: Blank
- Approx. 1 sec:
- Approx. 3 sec:
- Approx. 10 sec:

4.5 Initial Setting

To operate the oscilloscope, set initially the panel switches and controls as instructed in this section. For the storage mode, refer to Section 5.1.

Note: Be sure to rotate each control knob 30 degrees or more from the existing position. Note that the positional date of the control may not be correctly recognized unless it is turned as above.

- 1) Turn on the POWER ① switch.
- 2) Press the READOUT ⑤ knob the required number of times to select the readout intensity control function. Set the knob at a mid-position and check that readout is displayed on CRT. Adjust focusing with the FOCUS ④ control.
- 3) Set the switches and controls as follows.

Switch or Control	No.	Setting
INTEN	②	3 o'clock position
SCALE	⑤	Fully counterclockwise
VERT MODE	③⑨	CH1 only.
POSITION	④⑩	Mid-position
VOLTS/DIV	⑥	10 mV/DIV (displayed on CRT)
VAR	⑦	CAL'D (pushed-in state)
COUPLING	⑧	GND (AC or DC)
A.B TIME/DIV	①⑥	0.5 ms/DIV
VAR	①⑦	CAL'D (pushed-in state)
SWEEP MODE	②③	AUTO (top position)
TRIG SOURCE	②④	V-MODE, CH1 (top position)
TRIG CPLG	②⑤	AC (top position)
A/B TRIG	②⑥	A (disabled)
LEVEL AUTO	②⑦	AUTO
SLOPE	②⑧	+
TRIG LEVEL	③⑩	Mid-position (disabled)
CURSOR SW	③①	HO
SUB CURSOR SW	③②	Disabled

To be continued

885692

Switch or Control	No.	Setting
READOUT CONTROL	③③	Fully counterclockwise (HOLDOFF function off)
DVM SW	③④	Off
POSITION	②⑩	Position where trace is displayed at center of CRT
STORAGE MODE	⑤①	REAL (for digital type of oscilloscopes only)
HORIZ MODE	③⑥	A

- 4) When above setting is done, a trace will appear on CRT. If no trace appears even when more than 60 seconds has elapsed after the above setting is done, repeat the procedure of (3).
- 5) When the trace is displayed, adjust it with the INTEN ② control and FOCUS ④ control.
- 6) Adjust the trace so that it is parallel with the graticule lines by turning the TRACE ROTATION ③ control with a screwdriver. This adjustment will be necessary each time as you remove the oscilloscope is moved its direction.

4.6 Calibration of Probes

The probes act as wide frequency band attenuators. Unless they are properly adjusted for phase compensation, displayed waveform may be distorted and measuring errors may be introduced. Be sure to properly calibrate them before measurement.

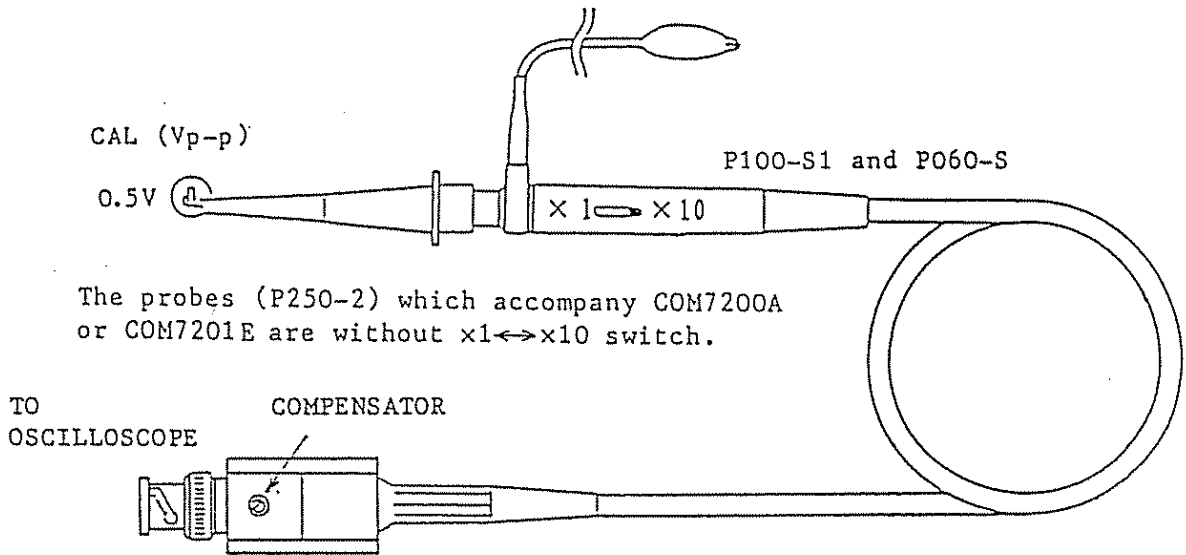

Figure 4.6

To calibrate the probes use the signal of the CAL ② terminal on the front panel of the oscilloscope and proceed as follows:

Connect one of the probes to the CH1 INPUT ③ terminal and set the VOLTS/DIV ⑥ switch at 10 mV. For Type P100-S1 or P060-S Probe, set the switch at $\times 10$. Connect the probe tip to the CAL terminal. Observing the waveform displayed on the CRT, adjust the compensator (see Figure 4-6) with a screwdriver so that an ideal waveform is obtained.

Calibrate the other probe for CH2 in the same method as above.

When using a probe with its switch set at $\times 10$, change the readout factor referring to Section 4.7.

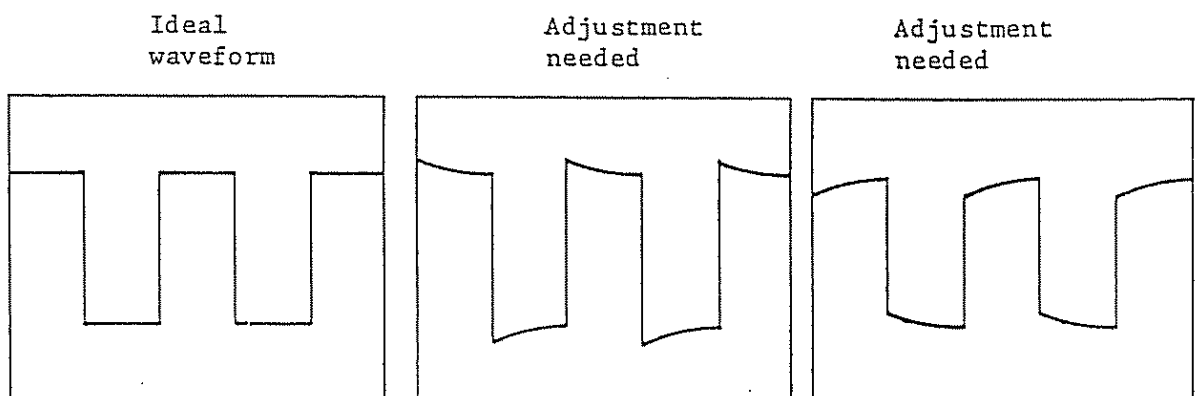

Figure 4-7

4.7 To Change Readout Factor for Probe

The values of vertical deflection factor and ΔV measurement displayed on the CRT readout are as that of the signal at the probe tip. When a 10:1 probe is used, the factor for displaying the value on the CRT readout can be changed to display directly the value at the probe tip.

To change the factor, proceed as follows:

For COM7200A, COM7100A or COM7060A, press the GND switch of COUPLING ⑨ ⑬ ⑮ ⑰ of the channel to which the probe is connected within the period the CRT is in the beam find status after pressing the INTEN ② knob once and releasing your hand from the knob.

For COM7201E, COM7101E or COM7061A, press the same switch together with the 2ND FUNCTION KEY ④③ switch. When this is done, the value indicated on the CRT readout is multiplied by a factor of 10 on the selected input and a message "P x10" is displayed on the CRT.

To reset the regular state from the above state, repeat the same procedure as above.

4.8 Beam Finder

When the trace is deflected and lost from the CRT screen or when its intensity is insufficient and it is undetectable, you may press the INTEN ② knob so that an intensified trace is displayed on the CRT screen for a few seconds.

The key acts also as a second function key to be pressed together with other keys, for such functions as self calibration, probe-use display change, resetting, etc.

4.9 2-channel Mode (except COM7201E, COM7101E and COM7061A in storage Mode)

If you press the CH2 key of VERT MODE ③⑨ selector in addition to the setting for CH1 single channel mode of Section 4.5 (3), the oscilloscope operates in a 2-channel mode with CH1 and CH2, the CH1 and CH2 indicator lamps illuminate, and the vertical deflection factors of these channels are displayed at the bottom of the CRT.

885695

When in this mode, the ALT or CHOP lamp of VERT MODE ③⑨ illuminates. Either the ALT or CHOP sweep mode is selectable. For measurement of rapidly changing signals or higher frequency signals, use the ALT sweep mode to sweep the traces alternately (if the CHOP mode is used, the displayed traces may become dotted lines due to chopping). For measurement of slowly changing signals or lower frequency signals, use the CHOP mode to sweep the traces being chopped by a high frequency (if the ALT mode is used, the displayed traces may flicker due to low-frequency alternate sweeps).

Regardless of the above, however, the CHOP sweep mode may be used even when a higher sweep speed is employed if there are irregular phenomena to be measured at the same time. In addition to the above, the ALT sweep mode may be used when the frequencies of the two channel signals are not correlated and alternate triggering is needed.

Any combination of two of the four channels (CH1 - CH4) can be selected with the VERT MODE ③⑨ switch for this 2-channel mode of operation.

4.10 ADD Mode (except COM7201E, COM7101E and COM7061A in storage mode)

When the ADD switch of VERT MODE ③⑨ is pressed and channels CH1 and CH2 only are selected, a waveform representing the algebraic sum of the two channel signals is displayed on the CRT. When the CH2 POSITION ③⑧ knob is pushed in and the INV lamp has illuminated, a waveform representing the algebraic difference between the two channel signals is displayed.

For accurate ADD operation, adjust in beforehand the vertical deflection factors of the two channels to the same value with VARIABLE ⑦ ⑩ controls.

When in the ADD mode, both POSITION ④⑩ ③⑧ controls are enabled. To maintain good linearity of the vertical amplifiers, use the central sections of the position controls.

885696

4.11 X-Y Mode (except COM7201E, COM7101E and COM7061A in storage mode)

As you press the X-Y key of HORIZ MODE ③⑥ selector, the X-Y lamp illuminates and the oscilloscope operates in an X-Y mode with the CH1 signal as X-axis signal. In this case the indicator lamps related to triggering go off and the switches related to triggering remain disabled. If the frequency counter function is selected by pressing the DVM switch ③④, however, the SOURCE ②④, CPLG ②⑤, LEVEL AUTO ②⑦, SLOPE ②⑧ and LEVEL ③⑩ are enabled and their indicator lamps illuminate.

If you press the X-Y switch when the oscilloscope is operating in the regular sweep mode and in CH1 or CH2 single channel mode or in CH1 and CH2 dual channel mode, the oscilloscope operation is automatically changed to an X-Y operation with CH1 as X-axis and CH2 as Y-axis.

By selecting with VERT MODE ③⑨ switch any one or combination of CH2, CH3 and CH4, operate as Y-axis channels in X-Y mode. In this case the traces are swept in the CHOP mode and the indicator lamps of the selected Y channels of VERT MODE ③⑨ illuminate.

To return to the regular mode from the X-Y mode, press the A, ALT or B switch of HORIZ MODE ③③.

4.12 3-channel or 4-channel Mode (except COM7201E, COM7101E and COM7061A in storage mode)

If you press all of the CH1, CH2, CH3 and CH4 switches of VERT MODE ③⑨ the oscilloscope operates in a 4-channel mode and four traces are displayed on the CRT. If you press the ADD switch also, fifth traces will be displayed representing an algebraic sum of the CH1 and CH2 signals.

As above, the oscilloscope is able to display from a single trace up to five traces simultaneously on its CRT screen. The traces can be successfully triggered and displayed by alternate triggering even when there are no correlations among the channel signal frequencies, provided that VERT MODE ③⑨ is set for ALT, LEVEL AUTO ②⑦ is set for OFF, and SOURCE ②④ is set for V-MODE.

885697

4.13 Voltage Measurement

The oscilloscope allows you three types of voltage measurement. First, voltage can be determined by means of the CRT graticule. Second, ΔV (differential voltage) between two points can be determined by means of cursors. Third, the CH1 input signal voltage can be directly measured with the internal digital voltmeter.

1) ΔV Measurement (except in ALT, B sweep mode or X-Y mode)

The ΔV lamp illuminates and two horizontal cursors (one with dotted line and the other with broken line) are displayed on the CRT as you press CURSOR SW ③① when HORIZ MODE ③⑥ is set for A sweep. Position of the broken line cursor is vertically adjustable with the READOUT control ③③. Move the cursor to the required measuring point with the control.

Next, press twice the READOUT control ③③ and the broken line cursor will become a dotted line cursor and the dotted line cursor will become a broken line cursor after both cursors becoming dotted line cursors. Now move the new broken line cursor to the required measuring point in the same manner as above.

The differential voltage is digitally displayed on CRT with the scale factor of VOLTS/DIV ⑥ ⑩ of CH1, except when in a single channel mode with CH2 or multi-channel mode with CH2 plus CH3 and/or CH4 in which case the scale factor of CH2 is employed.

When both cursors are broken lines, they are in the tracking mode and they can be moved on the CRT keeping the distance between them constant.

The range is adjustable with the READOUT control ③③ to approximately 1 DIV in upward and downward directions from the mid-position of the control knob. As you turn the control to the full clockwise or counterclockwise position (to the end position), the cursor moves automatically and continuously. To stop the moving cursor, turn the control in the reverse direction from the end position.

Measurement of ΔV with cursors is enabled only when the HORIZ MODE ③⑥ selector is set for the A sweep mode. It is disabled when the selector is set for the ALT, B, or X-Y mode.

885698

When in a single channel mode with CH3 or CH4 alone, or dual trace mode with CH3 and CH4, ΔV measurement is disabled and ratio measurement is enabled in its stead, and the measured voltage ratio is displayed on CRT readout.

2) DVM Measurement (except COM7201E, COM7101E and COM7061A in storage mode)

If you press the DVM SW ③④ when a signal is applied to CH1 input, the DVM lamp illuminates and the CH1 input signal voltage is measured by the internal DVM and digitally displayed at top left on the CRT screen.

When AC is selected by DVM SW ③④, the true-rms value of the signal for 20 Hz - 100 kHz is measured. If the input COUPLING ⑨ switch is set for AC, the rms value of the AC signal is measured; if the switch is set for DC, the DC + AC rms value is displayed. The displayed units of measure are V and V, respectively.

When DC is selected by DVM SW ③④, the DC voltage of the CH1 input signal is measured. For this DC voltage measurement, the input COUPLING ⑨ switch must be set for DC. (If it is set for AC, a symbol "?" is displayed on the CRT.) The displayed unit of measure is V.

When p-p is selected by DVM SW ③④, the peak-to-peak voltage of the CH1 input signal for 20 Hz - 10 MHz is measured. The displayed unit of measure is V, with suffix P for identification.

The DVM measurement is for CH1 input signal only. The signal is measured and displayed even when CH1 is not selected by VERT MODE ③⑨. Even when in the X-Y mode, the CH1 signal (X-axis signal) is measured and displayed if DVM SW ③④ is selected.

Note, however, that large measuring errors may occur for extremely large (such as overflowing from the CRT screen) or small signals.

When the STORAGE mode is selected by the MODE SW ⑤① DVM measurement ceases and no measured the oscilloscope to the REAL mode, DVM measurement resumes with the function settings as existed before.

885699

4.14 Voltage Ratio Measurement (except in ALT, B sweep mode or X-Y mode)

The ratio of the voltage of a signal with respect to the voltage of a reference signal can be measured. A typical example is measurement of the ratio of an overshoot voltage with respect to a reference voltage.

For voltage ratio measurement, proceed as follows: Display two cursors on the CRT with the procedure of Section 4.13 (1). Move the cursors to the 0% position and 100% position of the graticule with the READOUT control ③. Apply the signal to be measured to the CH1 input terminal ⑧ and adjust its amplitude to 5 DIV with the VARIABLE ⑦ control. A message "RATIO 100.0%" will be displayed on the CRT. Next, move the cursors to the positions for the required voltage section (for example, overshoot section of a pulse wave). The ratio (percent) of the section with respect to the reference amplitude (5 DIV for 100%) will be directly indicated on the CRT.

For voltage ratio measurement when in a single trace mode with CH1 or CH2 or when in a multi-trace with CH1 and other channels, set the VARIABLE ⑦ control to the UNCAL state. For voltage ratio measurement when in a single trace mode with CH2 or 2-trace mode with CH2 and ADD or multi-channel mode with channels except CH1, set the VARIABLE ⑩ control to UNCAL state. For voltage ratio measurement when in 2-trace mode with CH3 and CH4, the voltage levels of the input signals must be set at 5 DIV as displayed on the CRT.

885700

4.15 Time Interval Measurement (except COM7201E, COM7101E and COM7061A in storage mode)

The time interval ΔT (differential time or period) between two vertical cursors can be measured. (Typical examples are measurement of rise and fall time of pulse waves, and measurement of the period between two points on a signal.)

For time interval measurement, proceed as follows: When HORIZ MODE ③⑥ is set for A sweep, press CURSOR SW ③①. The ΔT lamp will illuminate and two vertical cursors, one with dotted line and the other with broken line, will be displayed on the CRT. Move the broken line cursor with the READOUT control ③③ to a measuring point on the waveform (for example, to the 10% amplitude point on a pulse wave). Next, press twice the READOUT control ③③.

The types of the cursor lines will be changed between dotted line and broken line, after both cursors have changed to broken lines. Move the new broken line cursor to another measuring point on the waveform (for example, to the 90% amplitude point on the pulse wave). The time interval between the two points (the rise time of the pulse wave in this example) is measured with the scale factor set by the A TIME/DIV ④⑥ switch and the measured value is digitally displayed on the CRT.

When both cursors are with broken lines, they are in the tracking mode and they can be moved on the CRT keeping the distance between them constant.

The range adjustable with the READOUT control ③③ is approximately 1 DIV to right and left from the mid-position of the control knob. As you turn the control to the full clockwise or counterclockwise position (to the end position), the cursor moves automatically and continuously. To stop the moving cursor, turn the control in the reverse direction from the end position.

Measurement of ΔT with cursors is enabled only when the HORIZ MODE ③⑥ selector is set for the A sweep mode. When it is set for the ALT or B sweep mode, ΔT measurement with delayed sweep can be done.

885701

4.16 Time Ratio Measurement (except COM7201E, COM7101E and COM7061A in storage mode)

The ratio (percent) of a time interval with respect to a reference time interval is measured using two vertical cursors as in the case of ΔT measurement. A typical example is measurement of duty cycle of pulsed waveforms.

To measure duty cycle of a pulse wave, for example, proceed as follows:
Set the oscilloscope as in the case of ΔT measurement. Adjust the sweep span of one cycle of the displayed waveform to 5 DIV (100%) with the SWEEP VARIABLE (17) control. (Hereafter, exercise care so that the set position of the control is not disturbed so far as this measurement is continued.) Move the two cursors to the two measuring points (rise and fall edge) of the pulse using the READOUT control (33). The duty cycle of the pulse wave will be digitally displayed in percent on the CRT.

4.17 Frequency Measurement

The oscilloscope allows you three types of frequency measurement. First, by determining the period of one cycle of the signal on the graticule and calculating the reciprocal of the period. Second, by $1/\Delta T$ measurement with cursors. Third, by direct measurement of the internal frequency counter displayed on the CRT.

- 1) $1/\Delta T$ Measurement (except COM7201E, COM7101E and COM7061A in ALT or B sweep mode of storage operation)

For $1/\Delta T$ measurement, proceed as follows: Set HORIZ MODE ③⑥ for A sweep; press CURSOR SW ③①. The $1/\Delta T$ lamp will illuminate and two vertical cursors, one with broken line and the other with dotted line, will appear on the CRT. Move horizontally the broken line cursor with the READOUT control ③③ to a measuring point (for example, to the rise up point of a pulsewave). Next, press twice the READOUT control ③③.

The types of cursor lines will be changed between dotted line and broken line, after both cursors being changed once into those with broken lines. Now move the new broken line cursor to another measuring point (for example, to the rise up point which is apart by one cycle from that where the previous broken line cursor was set). The signal frequency calculated as the reciprocal of the period between the two cursors with the scale factor set by A TIME/DIV ④⑥ will be digitally displayed on the CRT.

When both cursors are lines, they are in the tracking mode and they can be moved on the CRT screen keeping the distance between them constant.

The range adjustable with the READOUT control ③③ is approximately 1 DIV to right and left from mid-position of the control knob. As you turn the control to the full clockwise or counterclockwise position (to the end position), the cursor moves automatically and continuously. To stop the moving cursor, turn the control in the reverse direction from the end position.

Measurement of $1/\Delta T$ with cursors is enabled only when the HORIZ MODE ③⑥ selector is set for A sweep mode. When it is set for the ALT or B sweep mode, $1/\Delta T$ measurement with delayed sweep can be done.

885703

- 2) Measurement with Frequency Counter (except COM7201E, COM7101E and COM7061A in storage mode)

When the DVM function is enabled by pressing DVM SW ③④, the signal frequency of the channel selected as triggering signal source by the TRIG SOURCE ②④ switch is measured by the internal frequency counter and displayed on the CRT, as well as the signal voltage measured by the internal digital voltmeter is displayed.

The counter circuit is disabled when the TRIG SOURCE ②④ selector is set for the V-MODE for two channels or more. Even when an input signal is being applied, the counter circuit is disabled if the TRIG LED ②③ lamp is not illuminated indicating that no triggering is being accomplished.

Note that measurement may be unreliable when pulse widths are very narrow or when signal voltage is unreasonably low.

As you set the MODE SW ⑤① to the STORAGE mode, frequency measurement ceases and the measured frequency data disappears from the CRT readout as well as the voltage data measured by the DVM function disappears.

As you set the MODE SW ⑤① back to the REAL mode, frequency measurement and voltage measurement resume with the settings as existed before.

885704

4.18 Measurement of Phase Difference (except COM7201E, COM7101E and COM7061A in storage mode)

Phase difference between two signals of the same frequency can be measured. (A typical example is measurement of phase difference between input signal and output signal of an amplifier.) Measurement is done using vertical cursors and the measured value is displayed in degrees.

For this measurement, proceed as follows:

Set the oscilloscope as in the case for $1/\Delta T$ measurement. Apply the reference signal (for example the input signal of the amplifier) to the CH1 input terminal ⑧ of the oscilloscope, move the displayed waveform to the center of the CRT with the CH1 POSITION ③⑤ control, and adjust the time base with the SWEEP VARIABLE ①⑦ control so that one cycle of the signal is displayed with a span of 5 DIV. Next, apply the signal to be compared (for example the output signal of the amplifier) to the CH2 input terminal ⑫ and display its waveform with the same amplitude and at the same position as that of the CH1 signal waveform by adjusting the CH2 VOLTS/DIV ⑩ switch, VARIABLE ① control, and POSITION ③⑧ control. Move one of the cursors to the point where the CH1 input signal crosses the horizontal center line of the graticule and the other cursor to the point where the CH2 input signal crosses the horizontal center line. The phase difference between the two signals will be displayed on the CRT.

Note: When the TRIG SOURCE ②④ selector is set for the V-MODE, the phase difference measurement is unreliable as the alternate triggering function is brought into effect. The measured value may be unreliable also when the lengths of the cables used to connect the signals to the CH1 and CH2 input terminals ⑧ ⑫ are different or when there are other causes of signal delay in the connecting circuits.

885705

4.19 Delayed Sweep (except COM7201E, COM7101E and COM7061A in storage mode)

The oscilloscope allows you an alternate delay mode (alternate sweeps between intensity-modulated delay-preparation sweep and delayed B sweep) and delayed B sweep mode. For each of these two modes, either continuous delay sweep mode or triggered delay sweep mode (B TRG) can be selected.

1) Alternate Delay Mode (ALT)

This mode is for display of two traces--one is an intensity-modulated trace for preparation for delayed sweep and the other is a delayed B sweep.

As you change the HORIZ MODE ③⑥ selector from A to ALT, part of the trace being displayed on the A sweep is intensified and at the same time an other trace which is a magnified waveform of the intensified section is displayed on the B sweep for the full span of the CRT.

The length of the intensified section of the A sweep (the length which represents the B sweep time) is adjustable with the A, B TIME/DIV ①⑦ control set in the pulled out state. Both A sweep time and B sweep time are digitally displayed on the CRT.

The delay time (from the starting point of writing of the A sweep to that of the intensity-modulated section) is adjustable with the READOUT control ③③ by setting the CURSOR SW ③① to the DLY state. The adjustable range is approximately 1 DIV to right and left. As you turn the control to the full clockwise or counterclockwise position (to the end position), the cursor moves automatically and continuously. To stop the moving cursor, turn the control in the reverse direction from the end position. When in this mode of operation, the delay time together with characters "DLY" is displayed on the CRT readout.

If you press the SUB CURSOR SW ③② when the DLY lamp is illuminated, the HO and A \updownarrow B lamps will illuminate sequentially in addition to the DLY lamp. When the HO lamp is illuminated, the READOUT control ③③ acts as a holdoff time control. When the A \updownarrow B lamp is illuminated, the READOUT control ③③ acts as a trace separation control to move the delayed B sweep from the A sweep to ± 4 DIV or more. As you press again the SUB CURSOR SW ③② or press the READOUT control ③③, the DLY lamp alone illuminates.

885706

2) Delayed B Sweep Mode

Depending on sweep frequencies, the ALT mode may be inconvenient as the displayed waveforms may flicker or may become dim. To avoid this change the HORIZ MODE ③⑥ selector from ALT to B. The delayed B sweep will be displayed on the CRT, with less flicker and higher intensity.

When in the B sweep mode, the sweep speed can be made slower by turning counterclockwise the A,B TIME/DIV ①⑥ in the pulled out state. The speed, however, cannot be made slower than that of A sweep.

3) Triggered Delay (B TRIG) Mode

When in the continuous delay mode, the B sweep starts at the instant the delay time preset by the delay time control has elapsed. However, if you press the B TRIG switch of HORIZ MODE ③⑥ selector when in the ALT or B mode, the triggered delay mode is brought into effect. When in this mode, the B sweep starts at the instant the signal has crossed the B trigger level after the delay period has elapsed. Even when the magnification factor is large, the displayed waveform jitters less as the start of B sweep is controlled by B triggering.

Even when you turn the READOUT control ③③ to change the delay time, the intensity-modulated section of the waveform on the A sweep does not move continuously but it moves in steps at the point where the signal crosses the B trigger level.

As you press the B TRIG switch of the HORIZ MODE ③⑥, the AUTO LEVEL ②⑦, the TRIG SLOPE ②⑧ and the TRIG LEVEL ③⑩ are automatically changed to the B trigger mode and their green lamps illuminate as well as those of the TRIG SOURCE ②④ and the TRIG CPLG ②⑤, indicating that settings of these controls can be changed.

To change them to the A trigger mode, press the A/B switch ②⑥. The TRIG SOURCE ②④ and the TRIG CPLG ②⑤, however, can be set for the A or the B trigger mode irrespective of setting of the A/B switch ②⑥.

When the B TRIG switch is not pressed, all lamps are orange indicating that the switches are for A trigger mode.

885707

4.20 Time Interval Measurement with Delayed Sweeps

When the HORIZ MODE ③⑤ selector is set for the A sweep mode, time interval between two points on the displayed waveform can be measured by means of the cursors. Depending on the type of the displayed waveform, however, this measurement is not always accurate due to the difficulty of setting the cursors accurately at the required points. Time interval measurement with delayed sweeps is more accurate since this method allows to overlap accurately the required points of the waveforms displayed on two delayed B sweeps. For time interval measurement with delayed sweeps when the oscilloscope is operated with a single channel for example, proceed as follows:

- 1) Display the waveform on the CRT by adjusting the VOLTS/DIV, A TIME/DIV, and POSITION.
- 2) Set the HORIZ MODE ③⑤ to ALT. Operate sweep in the continuous delay mode by releasing from the B TRIG mode.
- 3) Set the CURSOR SW ③① to Δ T. An A-sweep waveform with two intensity modulated sections and a B-sweep waveform with sections representing the same intensity-modulated sections but with delayed timings will appear on the CRT. (See Figure 4-8 A.)
- 4) With the RREADOUT control ③③, move the two intensity-modulated sections to the positions between which the time interval is to be measure. It also is possible to move the two intensity-modulated sections in a tracking mode keeping the distance between them unaltered.
- 5) Pull out the A, B TIME/DIV ④⑥ and set the B sweep time for more fine viewing of the measuring points on the delayed B sweep. Now you may set the HORIZ MODE ③⑤ to the B sweep mode so that the B-sweep waveform alone is displayed. When in the B sweep mode, you may employ the $\times 10$ MAG function.
- 6) By adjusting the READOUT control ③③, overlap the two measuring points on the B sweep waveform. (See Figure 4-8 B.)

885708

7) The time interval measured as above will be displayed on the CRT read-out.

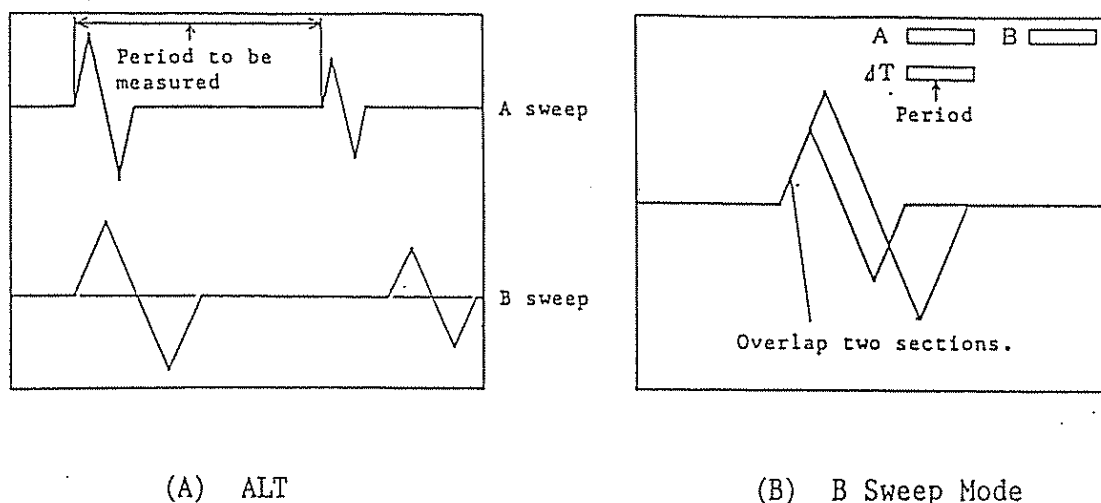

Figure 4-8. Time Interval (Period) Measurement with Delayed Sweep

The above example was for the case of a single channel mode of operation. By employing a 2-channel mode of operation, it is possible to measure time difference between two points on two different signals which are mutually related in time. When in the 2-channel mode, only one intensity-modulated section per channel is displayed on the A-sweep waveforms and also only one corresponding section per channel is displayed on the delayed sweep.

Note: When the repetitive rates of the two signals are different, pay attention when selecting the triggering signal source. In general, the one whose repetitive rate is slower is selected for the triggering source signal.

When the oscilloscope is operated with three or more traces, intensity-modulated sections are displayed as described in the following.

When the HORIZ MODE $\text{\textcircled{36}}$ is set for the ALT mode, the intensity-modulated sections on the A-sweep waveforms are displayed as follows:

885709

When in the 3-trace mode, one intensity-modulated section is displayed on each of the waveforms of the two leftmost channels as indicated at the VERT MODE ③⑨ and two intensity-modulated sections are displayed on the waveform of the remaining channel. For example, when in a 3-trace mode with CH1, CH2 and CH3, one intensity-modulated section is displayed on each of the CH1 and CH2 waveforms and two intensity-modulated sections are displayed on the CH3 waveform. (See Figure 4-9 A.)

When in a 4-trace mode, one intensity-modulated section is displayed on each of the channel waveforms. (See Figure 4-9 B.)

When in a 5-trace mode (four input signal traces plus one ADD trace), two intensity-modulated sections are displayed on the ADD trace.

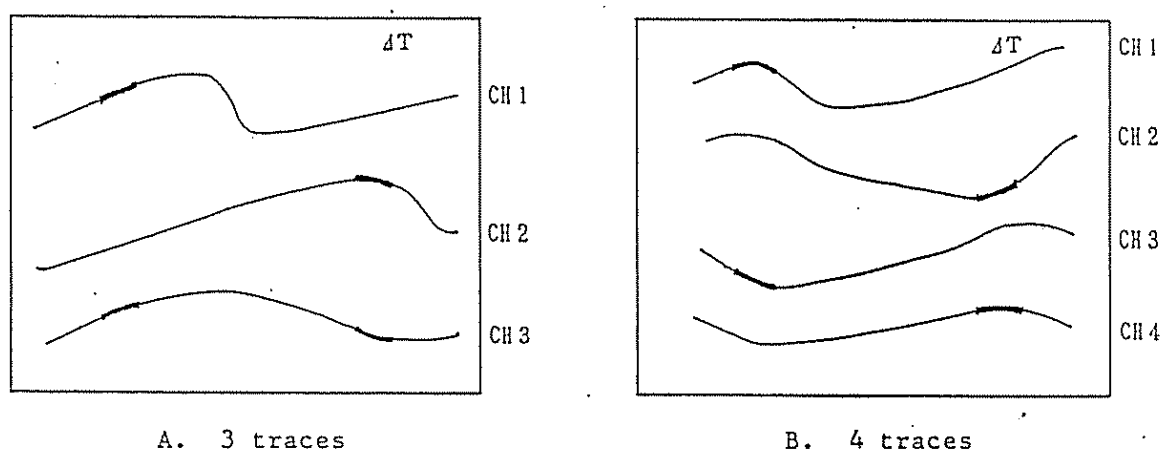

Figure 4-9. Multi-trace Delayed Sweeps

The priorities of traces are in the order of CH1, CH2, CH3, CH4, and ADD. When the number of traces is even, a pair of traces is formed in the due priorities and time interval between the pair of traces is measure. When the number of traces is odd, time interval between two points only on the trace of the least priority alone is measured.

When the HORIZ MODE ③⑥ is set for the CHOP mode or when the TRIG SOURCE ②④ is set for the V-MODE and the channel indicator lamps of two or more channels are on and sweeps are running in the alternate triggering mode, two intensity-modulated sections are displayed on each of the delay preparation waveforms, thereby allowing to measure time interval between two points on the waveform of each channel.

885710

5. STORAGE MODE (COM7201E, COM7101E, COM7061A)

5.1 Storage Operation

The COM7201E, COM7101E or COM7061A can be operated in a storage mode by pressing its STORAGE MODE ⑤① switch. This section describes the functions available when the oscilloscope is in the storage mode.

1) VERT Mode

The channel(s) to be displayed on the CRT can be selected with the VERT MODE ③⑨ selector when in the storage mode as well as when in the real mode. The ADD mode cannot be selected when in the storage mode, however. If the V-MODE is selected by the TRIG SOURCE switch when in the storage mode, triggering is made in the ALT TRIG mode as well as when in the real mode.

The ALT and CHOP modes of operation when the oscilloscope is set in the storage mode are as follows: When in the ALT mode, data of channels selected by the VERT MODE ③⑨ selector are acquired alternately for individual channels. When in the CHOP mode, data of the selected channels (CH1 and CH2 only are selectable in this case) are acquired simultaneously. (If you attempt to select a 3- or 4-channel mode or a 2-channel mode with CH3 and CH4 when the oscilloscope is in the CHOP mode, it will be automatically changed to the ALT mode.)

2) HORIZ Mode

Either a single time base mode (A sweep) or a delayed sweep mode (ALT, B sweep) can be selected with the HORIZ MODE ③⑥ selector.

When in the A sweep mode, the oscilloscope can operate with the storage function at all time base ranges of 5 s/DIV to 10 ns/DIV (20 ns/DIV for COM7101E and 50 ns/DIV for COM7061A). In this case, waveform display is in the ROLL mode if the time base is 5 s/DIV - 0.1 s/DIV or in the REPEAT mode if the time base is 2 μ s/DIV or faster.

Delayed sweep operation in the storage mode is available when the time base is 50 ms/DIV - 10 ns/DIV (20 ns/DIV for COM7101E and 50 ns/DIV for COM7061A). If you press the B TRIG switch when in the B sweep mode, the

oscilloscope operates in the triggered delay mode. (For the delayed sweep mode of operation, see Section 5.6.) If you set the A TIME/DIV selector at 0.1 s/DIV or slower when the oscilloscope is operating in the triggered delay mode, it is automatically changed to the A sweep mode with the ROLL display.

3) REPEAT Mode

When in the repeat mode, waveform data is acquired in an equivalent time sampling method--that is, data of the waveform to displayed on the CRT is sampled being divided into a multiple number of sampling, thereby allowing to acquire data of signals whose frequencies are higher than the maximum effective storage frequency available in the realtime sampling method.

Of the COM7XX1A/E Series Oscilloscopes, the maximum realtime sampling rate is 20M samples/sec. By employing the equivalent time sampling method for the 2 μ s/DIV or faster ranges, data of repetitive signals can be acquired with sampling rates of 100M samples/sec to 10G samples/sec (5G samples/sec for COM7101E or 2G samples/sec for COM7061A).

Since a random sampling method is employed for equivalent time sampling, the pretriggering function is effective even when the oscilloscope is in the REPEAT mode, allowing you to measure data which existed before triggering as well as when in realtime sampling.

Note: When in the REPEAT mode, data of the displayed waveform is acquired by dividing into a multiple number of sampling. Therefore, data can be correctly acquired only of "repetitive" signals.

4) ROLL Mode

The ROLL mode allows you to view continuously on the CRT a slowly changing signal or a signal of very low repetitive frequency. The waveform displayed on the CRT flows from right to left, with the newest data displayed on the right hand end of the CRT.

885712

If you employ a regular triggering mode to display the waveform of a very slowly changing signal, quite a long period elapses before the waveform is swept for the full sweep cycle and, even though the waveform may change meantime, such change cannot be known until such change point is swept by the next sweep cycle. This rather intermittent display is inconvenient for setting of triggering conditions. If you employ the ROLL mode, a waveform flowing from right to left is continuously displayed on the CRT, irrespective of triggering allowing you to pause acquisition of further data by pressing the PAUSE ④④ switch at the instant you have noticed on the CRT a waveform you may require.

The ROLL mode is automatically selected as you select a time base of 5 - 0.1 s/DIV. However, the oscilloscope is automatically reset from the ROLL mode if you select a multi-channel ALT mode.

Types of the ROLL mode of operation are selectable with the MODE ②③ selector as shown in Table 5.1.

Table 5.1

MODE Selector		Type of ROLL Mode
AUTO		Displayed waveform flows continuously, irrespective of triggering. Suitable for continuous viewing of the waveform of a signal changing very slowly.
	VIEW TIME OFF	
NORM	VIEW TIME ON	Displayed waveform flows continuously until the input signal meets the triggering conditions and the triggering point which has been set by the TRIG POINT ④⑧ is reached. After this point is reached, the displayed waveform remains stationary for the period preset with the VIEW TIME ④⑦ and then it resumes flowing.
SINGLE		Displayed waveform flow continuously until the input signal meets the triggering conditions and the triggering point which has been set by the TRIG POINT ④⑧ is reached. After this point is reached, the displayed waveform remains stationary.

885713

When waveform is displayed in the ROLL mode with the SINGLE sweep, sweep is reset to the READY state when a HOLDOFF period (period during which triggering is disabled and the roll operation continues) corresponding to 10 DIV's has elapsed after the RESET lamp illuminates to indicate that sweep is ready to run by triggering. When triggering is effected, the TRIG lamp ②⑨ illuminates and sweep runs in the ROLL mode until the triggering point on the displayed waveform reaches the point preset by the TRIG POINT ④⑧. Then the displayed waveform becomes stationary.

When waveform is displayed in the ROLL mode with the NORM sweep and with the VIEW TIME control set for a certain period, although the roll operation will resume after the view time has elapsed, the initial period corresponding to 10 DIV's is suppressed as a HOLDOFF period (during which triggering is disabled and the TRIG lamp does not illuminate even if a valid trigger signal is applied). After the HOLDOFF period has elapsed, triggering is enabled.

Thanks to the HOLDOFF period, the pretrigger function can be effectively employed to display the section which existed before triggering, as illustrated in Figure 5-1 taking an example from the case of a SINGLE sweep operation.

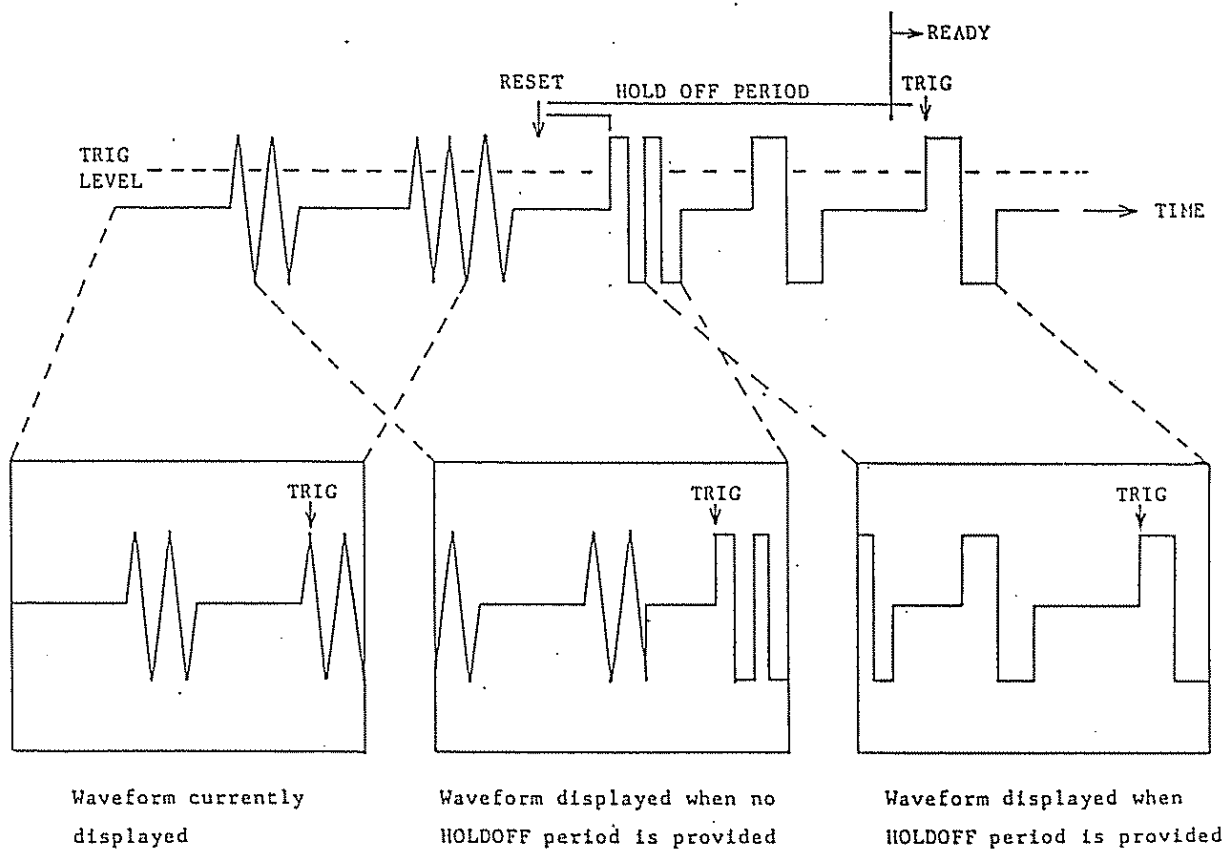

Figure 5-1. Waveforms Displayed in ROLL mode with SINGLE Sweep

When in the ROLL mode, the TRIG LAMP ②9 may go off for a short period in spite of the fact that a valid trigger signal is being applied. Before the sweep ends in the SINGLE sweep mode in the ROLL mode, the TRIG and READY lamps may go off or may go off once and then illuminate and go off again after the sweep is over. Regardless of such lamp indications, the triggering for the ROLL operation is valid and waveform data is acquired normally.

885715

5) Time Base Magnification and Interpolation

When in the state that acquisition of data is paused by pressing the PAUSE ④ switch, the time base for the displayed waveform can be magnified. The center of magnification point is indicated with a MAG symbol, whose location is adjustable in 1-DIV steps with the TRIG POINT ④. The magnification factor is adjustable for a range of 1 - 100 times with the TIME/DIV selector.

As the waveform is magnified, the number of the sampling points of the displayed part of the waveform is reduced. In this case, data for intermediate points are provided by interpolation. Two types of interpolation, namely, PULSE interpolation and SIN interpolation are selectable with the RESPONSE ⑤.

PULSE interpolation is made by connecting each two adjoining sampling points with a straight line. An waveform substantially identical with the original sin waveform can be restored if there are more than approximately 10 sampling points per cycle. This type of interpolation is suitable for interpolation of pulsive waves. If the peak value of the original waveform is not sampled, however, the waveform restored by PULSE interpolation will not be identical with the original waveform.

SIN interpolation is suitable for interpolation of sinusoidal waves. A waveform substantially identical with the original waveform can be restored if there are 2.5 or more sampling points per cycle.

6) SINGLE SWEEP Operation When in Storage Mode

If should be noted that, unless the instrument is set in the PAUSE state, all waveform data acquired with the SINGLE SWEEP operation in the STORAGE mode will be lost and a base line will be displayed at the position corresponding to the POSITION control setting as you change the TIME/DIV SW ⑥.

If the oscilloscope is set for the SINGLE SWEEP mode in the repeat mode range, irrespective of time base setting, waveform captured at a rate of 5 μ S/DIV is magnified with interpolation for display.

For example, when the oscilloscope is operated with a single channel at the 0.1 $\mu\text{s}/\text{DIV}$ range in the SINGLE SWEEP mode, the waveform displayed on the CRT has already been magnified by a factor of 50.

$$5 \mu\text{s}/\text{DIV} \div 0.1 \mu\text{s}/\text{DIV} = 50$$

Thus, with COM7201E and COM7101E, magnification is available only up to the 50 ns/DIV range.

The SINGLE SWEEP mode is unavailable at the 20 ns/DIV or 10 ns/DIV range with the COM7201E or COM7101E.

o SINGLE SWEEP Operation When in Storage Mode

When the VERT MODE (39) is set for a multi-channel ALT mode, the waveform data of the channels of the first highset priority is acquired by the first sweep cycle and that of the second highest priority is acquired by the second sweep cycle. (The priorities of the channels selected by the VERT MODE (39) are higher in the order of elder numbers, namely, in the order of CH1, CH2, CH3, and CH4.)

However, if you operate the A, ALT of B of HORIZ MODE (36) or the TIME/DIV (16) before the waveform data of all of the set channels is completely acquired, all data of all channels thereto been acquired is cleared and the base lines are displayed at the positions as set by the POSITION controls of respective channels.

If you operate the PAUSE switch before the waveform data of all of the set channels is completely acquired, although sweep magnification with the TIME/DIV (16) can be done, acquisition of waveform data after resetting from the PAUSE state resumes starting by the channel of the highest priority.

Also, if you change the MODE (23) from NORM to SINGL, all data of all channels thereto been acquired is cleared and the base lines are displayed at the positions as set by the POSITION controls of respective channels. When in the PAUSE state, although the stored waveform data can be held, the sweep mode cannot be changed from the NORM to the SINGL.

885717

7) ENVELOPE Mode

When in the ENVELOPE mode, the maximum or minimum value between each two adjoining sampling points is stored as data and an waveform is displayed by connecting with a straight line between each two data value points. By this function, this mode allows you to detect even very narrow pulses (glitches) which may exist between sampling points and are unable to be detected when in the normal data acquisition mode, and also allows you to discriminate aliasing.

Aliasing may occur when the input signal frequency has become higher than one-half of the sampling frequency (Nyquist's theorem). When the input signal is a sinusoidal wave and its frequency has become close to an integer-multiplication frequency of the sampling frequency, an apparently decent sinusoidal wave may be displayed on the CRT, deceiving you into judging that its data has been correctly acquired. The ENVELOPE mode allows you to discriminate such aliasing.

Glitches are very elusive and can hardly be detected, while successful detection and seizure of glitches are essential for analysis of digital instruments and devices. The ENVELOPE mode allows you to capture such glitches.

8) VIEW TIME Switch

When in the regular mode of operation, a new waveform is displayed immediately after the data for a full sweep cycle is acquired and this operation is continuously repeated. When you want to observe the same waveform for a long period, you may press the PAUSE (44) switch so that acquisition of new data is paused.

When you want to display the same waveform for a certain period and to display a new waveform after this period has elapsed and to repeat this operation, you can set the period with the VIEW TIME (47) switch. Each time as you press the switch, the period is changed as 1 sec → 3 sec → 10 sec → OFF (continuous) → 1 sec.

If you set the VIEW TIME switch at a certain period when the display is in the ROLL mode and the MODE ②③ selector is set for the NORM mode, the roll operation is paused for the set period after the trigger signal is applied. After the set period has elapsed, the roll operation resumes.

The VIEW TIME switch is disabled when the oscilloscope is in the SINGLE SWEEP mode or in the REPEAT mode, or when the oscilloscope is set in the ROLL mode and the MODE ②③ selector is set for the AUTO mode.

9) PAUSE Switch

As you press the PAUSE switch, acquisition of waveform data is paused and a message "PAUSE" is displayed on the CRT. As you press it again, acquisition of waveform data resumes. When in the PAUSE state, the time base of the displayed waveform can be magnified up to 100 times in 6 steps with the TIME/DIV switch.

When in the PAUSE state, the switches and controls except the below-mentioned ones are locked in the existing states and cannot be changed.

RESPONSE	⑤⑩
MAG POINT	④⑧
REF MEMORY	④⑥
SAVE	④⑤
CURSOR SW	③① (only when in A sweep mode)
V POSITION	③⑤, ③⑦, ③⑧, ④⑩
H POSITION	②⑩
A,B TIME/DIV	①⑥

Switches and controls of CRT circuit

10) REFERENCE Memory and SAVE Switch

The COM7XX1A/E Series Oscilloscopes have a REFERENCE memory (four units) which is used in a rather offline mode to store data for later use, in addition to the DISPLAY memory which is used in a rather online mode to store data of the waveform currently displayed on the CRT.

The REFERENCE memory is backed up with a battery and the data stored in it is not lost even when the POWER switch of the oscilloscope is turned off.

The REFERENCE memory may be used to compare the current acquired waveform with the reference waveform which has been stored in the REFERENCE memory. A typical example is that, on the adjusting line of a manufacturing plant, the waveform of the completely adjusted products is stored in the REFERENCE memory and the waveforms of the products being manufactured are compared with the former waveform as a reference.

The waveform stored in the REFERENCE memory can be called up onto the CRT screen by pressing the REF MEMORY (46) switch.

To save data of the DISPLAY memory by transferring it to the REFERENCE memory, press the PAUSE (44) switch to pause acquisition of new data, select the required REFERENCE memory by pressing the REF MEMORY (46) switch, and then press the SAVE (45) switch.

Through a GP-IB system, data can be written onto or read from the REFERENCE memory.

The four units of REFERENCE memory are assigned depending on the number of channels selected by the VERT MODE (39) selector as follows:

1-channel mode: One of units 1 - 4 can be selected with the REF MEMORY (46) switch at a time, allowing you to use the four units in turn to save up to four waveforms. Each time as you press the REF MEMORY (46) switch, the unit number advances in the order of 1 → 2 → 3 → 4 → OFF → 1.

2-channel mode: A combination of units 1 and 2 or that of units 3 and 4 can be selected. Up to two waveforms per channel can be saved. To the odd number memory units, the left hand channels as indicated at the VERT MODE ③⑨ switches are assigned. Each time as you press the REF MEMORY ④⑥ switch, the unit number advances in the order of 1-2, → 3-4 → OFF → 1-2.

3-channel mode: The memory units of the numbers the same with those selected by the VERT MODE ③⑨ switches are assigned. Each time as you press the REF MEMORY ④⑥ switch, the memory units are turned on or off.

4-channel mode: All memory units are turned on at the same time, assigned to the respective channel numbers. Each time as you press the REF MEMORY ④⑥ switch, the memory units are turned on or off.

Settings with the REF MEMORY ④⑥ for the above modes are done mutually independently for respective modes. The off states of the REFERENCE memory units also are set mutually independently for respective modes. Therefore, when none of the REFERENCE memory units are used in all of the modes, set each of them to the off state.

Assume a case that REFERENCE memory units 3 and 4 are selected for the 2-channel mode only. In this case, as you select the 2-channel mode with the VERT MODE ③⑨, the waveforms stored in REFERENCE memory units 3 and 4 is displayed on the CRT.

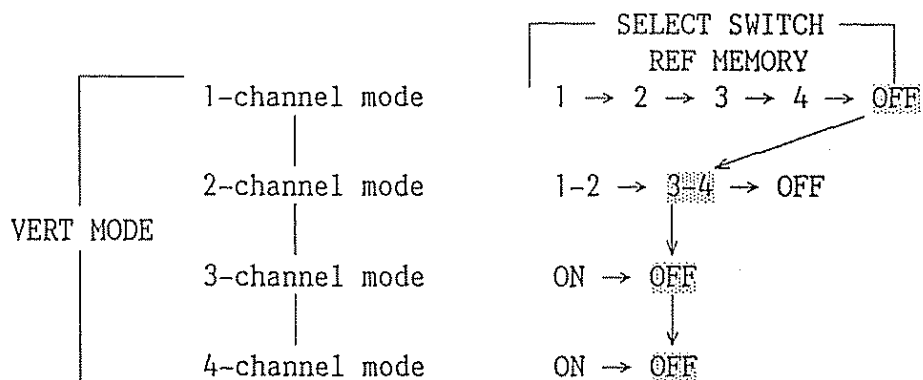

885721

5.2 Effective Storage Frequency and Frequency Bandwidth

The frequency characteristics of a digital oscilloscope depends on its effective storage frequency and frequency bandwidth. The maximum frequency of a sinusoidal wave signal which can be stored depends largely on the sampling rate and processing of the acquired waveform data. The maximum storable sinusoidal wave signal frequency is referred to as "effective storage frequency."

The sampling rate is determined by setting of the TIME/DIV $\text{\textcircled{B}}$ selector. The horizontal axis resolution of the COM7XX1A/E Series Oscilloscopes is 10-bit and a waveform is displayed with 100 data points/DIV on the horizontal axis.

When the TIME/DIV selector is set at the 1 ms/DIV range for example, the sampling period is 10 μ s and the sampling rate is 100 kHz. The sampling rate in general is expressed as follows:

$$\text{Sampling rate} = (\text{No. of sampling points per DIV}) \div (\text{TIME/DIV})$$

With SIN interpolation, the original waveform can be substantially restored if there are 2.5 or more sampled points per cycle. When a waveform is sampled with a sampling frequency of 100 kHz, the maximum restorable frequency is 40 kHz (100 kHz \div 2.5 points = 40 kHz). Thus, the effective storage frequency with SIN interpolation can be expressed as follows:

$$\text{Effective storage frequency} = (\text{Sampling rate}) \div 2.5$$

Thus, the original waveform can be substantially reproduced provided that the stored signal has no frequency components higher than the effective storage frequency.

With PULSE interpolation, the original waveform can be substantially re-stored if there are 10 or more sampled points per cycle. Therefore, the effective storage frequency with PULSE interpolation can be expressed as follows:

$$\text{Effective storage frequency} = (\text{Sampling rate}) \div 10$$

The frequency bandwidth is not affected by the sampling rate and remains the same at all time base ranges. When in the REPEAT mode, especially at ranges 0.2 $\mu\text{s}/\text{DIV}$ or higher, the effective storage frequency is calculated to be 200 MHz or higher. Actually, however, since it is limited by the frequency bandwidth and is 100 MHz (-3 dB) for COM7201E and COM7101E or 60 MHz (-3 dB) for COM7061A.

885723

TIME/DIV	Sampling Rate (samples/sec)	Effective Storage Frequency (Hz) Note 1	Sweep Mode		STORAGE Mode	VIEW TIME	Interpolation		Remarks
			ALT/B	A			SINE	PULSE	
5 s	20s	8			Note 2	Note 3			<p>Note 1: Effective Storage Frequency (F) with SINE Interpolation</p> $F = \frac{\text{Sampling rate (Hz)}}{2.5}$ <p>When in SINGLE SWEEP mode with 5 μs/DIV or faster ranges: F = 8 MHz maximum</p> <p>Note 2: ROLL Mode The ROLL mode is automatically released when in the single channel mode or in CHOP mode with two channels, or when in multi-channel ALT mode.</p> <p>Note 3: VIEW TIME The VIEW TIME function is disabled if the MODE $\text{\textcircled{3}}$ is set for AUTO when in ROLL mode with time base of 5 - 0.1s/DIV ranges. When in SINGLE SWEEP or REPEAT mode, the VIEW TIME function is disabled at all ranges of time base.</p> <p>Note 4: Repetitive signal</p>
2	50	20			ROLL				
1	100	40			MODE				
0.5	200	80							
0.2	500	200							
0.1	1K	400							
50 ms	2K	800							
20	5K	2K							
10	10K	4K							
5	20K	8K							
2	50K	20K							
1	100K	40K							
0.5	200K	80K							
0.2	500K	200K							
0.1	1M	400K							
50 μ s	2M	800K							
20	5M	2M							
10	10M	4M							
5	20M	8M							
2	50M	COM7201E, COM7101E							
1	100M	100MHz -3dB							
0.5	200M	COM7061A							
0.2	500M	60MHz							
0.1	1G	-3dB							
50 ns	2G	Note 4							
20 ns	5G								
10ns	10G								
		Equivalent time sampling							
		Realtime sampling							
		Magnified with interpolation when in SINGLE SWEEP mode							
		ENVELOPE Mode							
		Note 2							
		Note 3							

Table 5.2 Storage Mode

5.3 ΔT , $1/\Delta T$ and ΔV Measurement with Cursors

When in the storage mode and the HORIZ MODE (36) selector is set for A sweep, ΔT , $1/\Delta T$ and ΔV measurement with cursors can be performed as when in the real-time mode. When in the ALT or B sweep mode, however, this measurement is unavailable. Voltage ratio, time ratio and phase measurement are unavailable when in the storage mode.

5.4 DVM and Frequency Counter

The internal digital voltmeter and frequency counter are disabled when in the storage mode. To enable them, use the realtime mode (set the MODE (51) switch to the REAL time).

5.5 Delayed Sweep

Even when in the storage mode, magnification with B sweep is available as in the realtime mode.

As you set the HORIZ MODE (36) selector to ALT, an A-sweep waveform with the triggering point changed to the left hand end (0 DIV) position of the graticule (the latter is instead of an intensity-modulated delayed trace and B sweep in the case of the realtime mode) are displayed on the CRT.

At the top of the CRT screen, symbol $\overset{\text{DLY}}{\downarrow}$ which indicates the starting point of magnification is displayed instead of symbol $\overset{\text{TRIG}}{\downarrow}$ which indicates the triggering point when in the A sweep mode. Move the starting point symbol to the required point with the READOUT control (33). As you set the HORIZ MODE (36) selector to B sweep, waveform will be displayed on delayed B sweep.

The ALT and the B sweep modes are unavailable when the time base is at the 5 - 0.1 s/DIV ranges. When in the B sweep mode, triggered delay sweep with the B TRIG switch is available. When in the ALT sweep mode, the B TRIG switch is disabled.

885725

5.6 PENOUT Signal

Data stored in the reference memory and displayed on the CRT can be delivered via rear terminals of the oscilloscope for an external X-Y recorder.

For recording, connect the PEN Y OUT (57), PEN X OUT (56) and SYNC OUT (55) terminals of the oscilloscope to the Y INPUT, X INPUT and PEN UP/DOWN terminals of the X-Y recorder, respectively.

The X- and Y-axis output signals are 100 mV/DIV and the SYNC output signal is of a TTL level.

When in the PAUSE state, as you press the X-Y switch of the HORIZ MODE (36) together with the 2nd FUNCTION KEY (43), the X-Y recorder pen will move to the starting point of recording. In several seconds as the pen is set down onto the recording paper by the SYNC OUT signal, the X-Y recorder starts drawing the waveform data which has been stored in the reference memory.

On the CRT screen, the waveform is traced with a beam spot in the same manner as it is drawn with the pen on the X-Y recorder. Since the pen drive speed rate in the X direction is changed with respect to the amplitude in the Y direction of the waveform to be recorded, almost any model of X-Y recorder can be used (without requiring any high speed model of X-Y recorder).

When the pen has moved to the end point of waveform drawing, the pen is lifted up from the recording paper, remains in this position for several seconds, and then moves to the starting point of recording. Then the oscilloscope is reset from the PEN OUT mode to the PAUSE state.

When two or more reference memory units are indicated on the CRT readout, the above sequence is repeated to draw waveforms of all memory units and then the oscilloscope is reset from the PEN OUT mode.

To abort the above sequence halfway, press the LOCAL (2nd) switch of GP-IB (43). The oscilloscope will be reset from the PEN OUT mode to the PAUSE state.

885726

6. GP-IB INTERFACE

6.1 General

The oscilloscope complies with GP-IB (IEEE 488-1978), allowing itself to be remote-controlled from and to transact data with a host computer and other devices. The major functions available by this provision are as follows:

- (1) Panel control: Panel keys can be remote-controlled from an external controller or other device.
- (2) Step control: Panel settings of up to 100 types can be stored in internal step memory of the oscilloscope, and the panel can be instantaneously set to the required setting by giving a STEP command.
- (3) Sending of data: Data of stored waveforms, DVM or cursor measurements can be sent to a controller or other device.
- (4) Receiving of data: Waveform data received from the host computer can be stored in the reference memory.
- (5) Direct copy by GP-IB plotter:
When in the STORAGE mode, waveform data and other informations can be directly sent to a GP-IB plotter (HP-GL compatible type), without requiring any controller.

The GP-IB (General Purpose Interface Bus) allows to makeup a programmable instrumentation system by connecting various devices provided that they meet the requirements of the interface bus system.

The signals are transmitted in an 8-bit-parallel byte-serial format on a bidirectional bus. Data is transmitted in a 3-wire handshake system.

For each of the devices connected on the bus, one or more of the functions can be specified talker, listener or controller.

885727

Data can be sent from a device designated to be a talker to one or more devices designated to be listeners. The controller controls sending/receiving of data and manages interfacing of the devices connected on the bus.

The bus is comprised of 8 data lines, 3 handshake lines and 5 bus management lines (16 lines in total) plus a ground line. In the below illustration, DIO1 - DIO8 are data bus; NDAC, NRFD and DAV are handshake bus; and ATN, EOI, IFC, SRQ, REN are management bus.

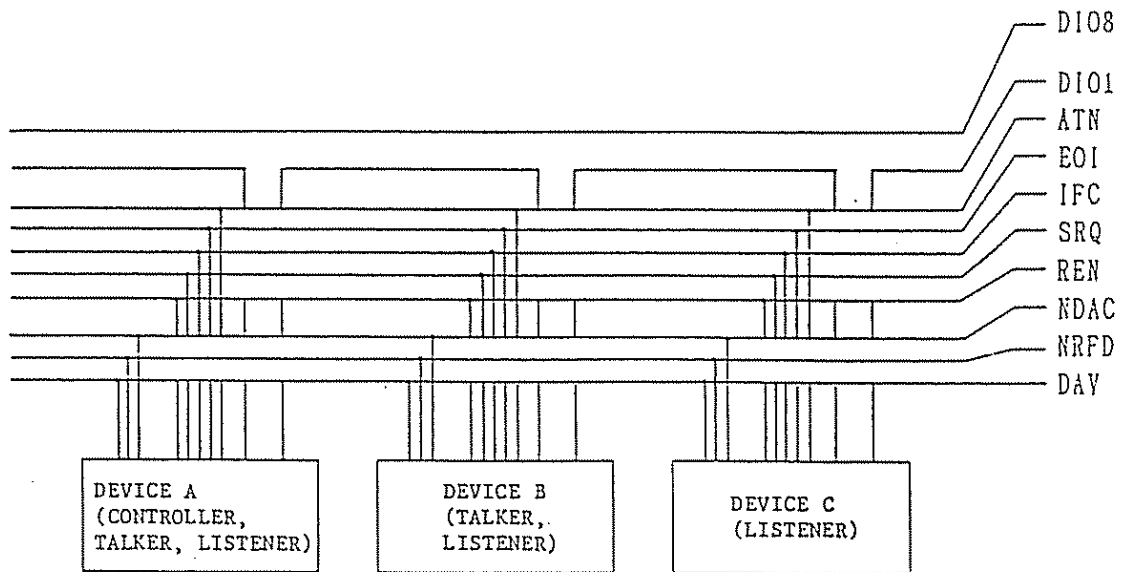

885728

6.2 GP-IB Specifications

6.2.1 Standards

ANSI/IEEE 488-1978

6.2.2 Interface Functions

Code	Function
SH1	With all SH functions
AH1	With all AH functions
T5	With basic talker function, serial poll function, talk only function, and talker release function by listener designation.
L3	With basic listener function, listen-only function and listener release function by talker designation
SR1	With service request function
RL1	With remote/local change function
PP0	Without parallel polling function
DC1	With device clear function
DT0	Without device trigger function
C0	Without controller function

885729

6.3 Descriptions for Operation

6.3.1 Remote Status and Local Status

(1) Description of Front Panel and Initial State of Remote mode

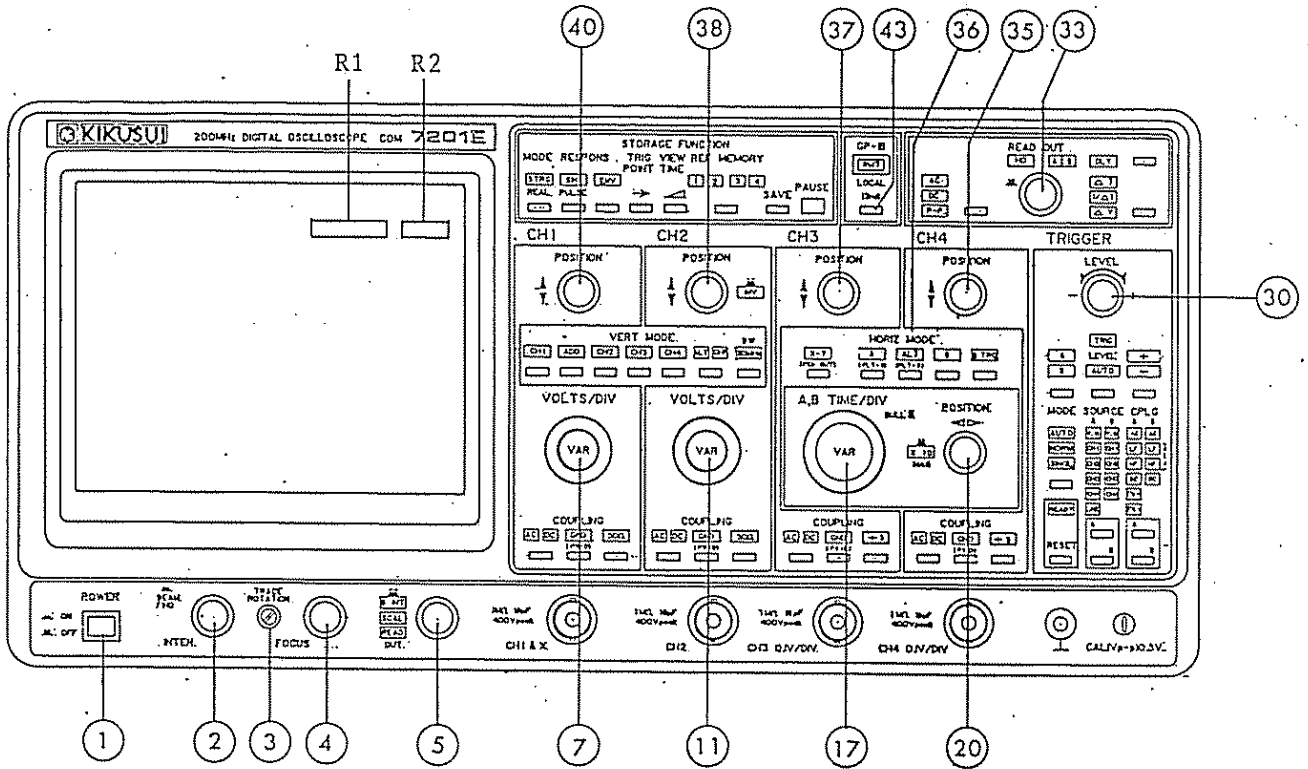

LOCAL SW (43)
(2nd FUNCTION KEY)

This switch changes the oscilloscope from remote status to local status.

When the oscilloscope is set to remote status by an external controller through GP-IB, panel keys except the ones mentioned in the below table are disabled. As you press this key, the oscilloscope is changed to local status and panel keys are enabled.

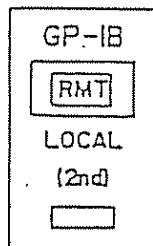

When the oscilloscope is designated to be in LLO (local lockout) status, this key is disabled and message "LOCKOUT" is displayed at the location of R1 on CRT indicated in the illustration of front panel.

The RMT lamp illuminates when in remote mode. It goes off when in local mode.

Swath or Control	Function Which Differs from When in Local Status
POWER ①	See Note 1.
INTEN ②	Offset can be applied through GP-IB.
TRACE ROTATION ③	
FOCUS ④	
B INT, SCALE, READOUT ⑤	SCALE and READOUT can be ON/OFF controlled through GP-IB.
VARIABLE ⑦ ⑪	
VARIABLE ⑰	
POSITION ⑳	
POSITION ⑳ ㉓ ㉔ ㉕	Offset can be applied through GP-IB. Acts as vernier control.
LEVEL ㉖	The same as above
READOUT CONTROL ㉗	The same as above

Note 1: Turn on power of all of the devices connected on the bus, even of devices which are not currently used.

When the oscilloscope is changed from the local status to the remote status, the items mentioned in the following table are changed as mentioned there. Other items remains in the local status.

Item	Initial State
INTEN	0 (center)
POSITIONS	0 (center)
A/B LEVEL	0 (center)
A/B SEPARATION	0 (center)
CURSOR	0 (center) after executing MOVE command
EOI	ON
SRQ	ON
WAVE CODE	BINARY
START	0
END	7

885731

HORIZ MODE ③⑥ As you press this switch together with the 2nd
(PLT 1), (PLT 2) .FUNCTION KEY ④③ when in the STORAGE mode, a
message "PLOT OUT" is displayed at R2 shown in
the illustration and waveform data is sent to
the GP-IB plotter. This function is available
only when the GP-IB switches of the oscillo-
scope are set for the TALK ONLY mode and those
of the GP-IB plotter for the LISTEN ONLY mode.

PLT 1

2nd + "A": Data is delivered with scale
double of that of CRT graticule.

PLT 2

2nd + "ALT": Data is delivered with scale
identical with that of CRT
graticule.

885732

(2) Description of Rear Panel and Setting of Delimiters

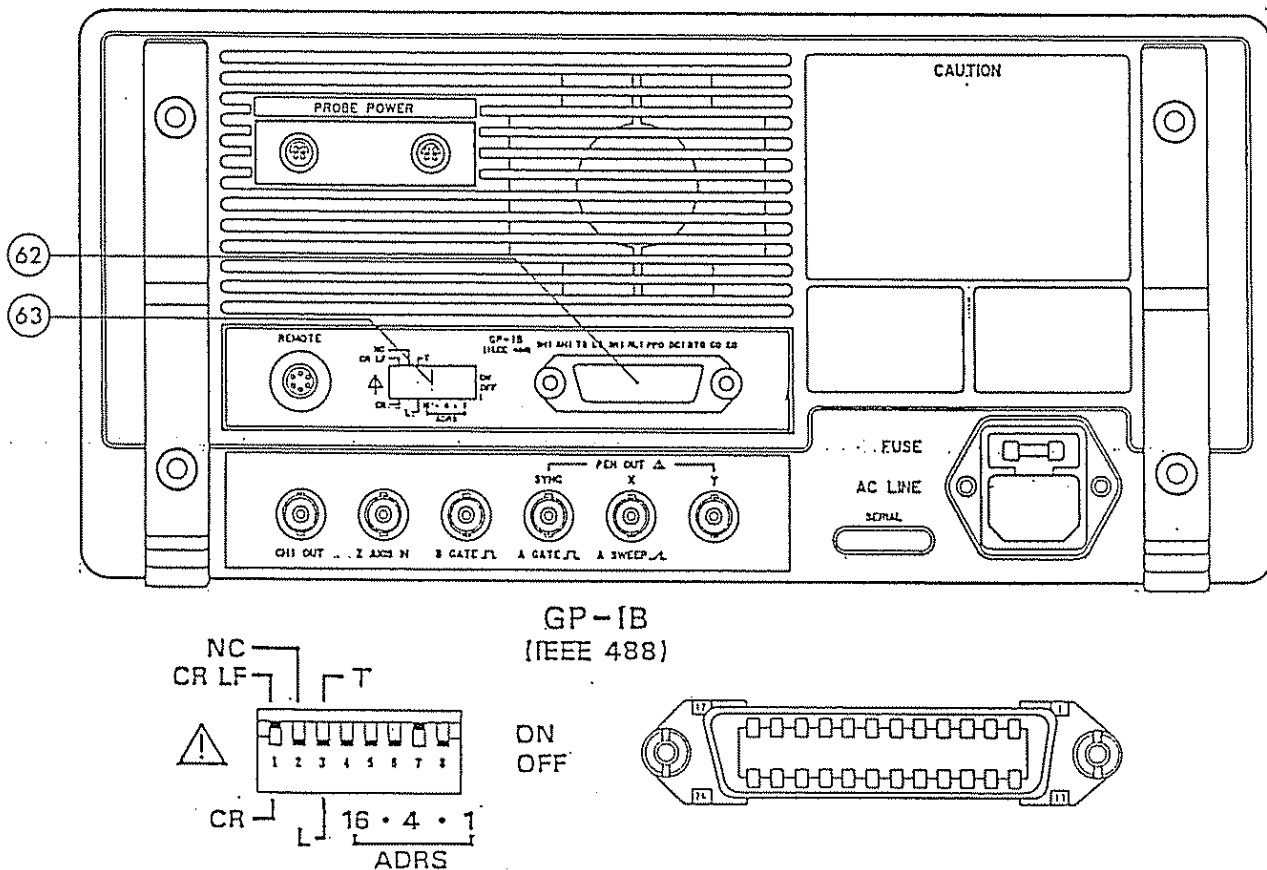

GP-IB Connector 62 24-pin connector which accepts GP-IB cable.

Note: When stacking up units by using piggy-back connectors, up to three units are allowable.

GP-IB Switches 63 DIP switches to set oscilloscope address (MLA, MTA) and delimiters

885733

Address Setting

For address setting, use the five or six rightmost ones of the DIP switches.

o Normal Address (0 - 30)

The ADRS section of the DIP switches is marked "16.4.1", which stands for "16 8 4 2 1". The set address number is the sum of the switches set in the

ON position. When all switches are set in the OFF position, the address number is 0. To set the address number at 19 for example, set the switches

as follows: Since $19 = 16 + 2 + 1$, set the "16", "." (which stands for 2) and "1" switches in the ON position.

Note: When the oscilloscope is shipped from the factory, the address number is set at 2.

o TALK ONLY

Set all switches of the ADRS section in the ON position and the T/L switch (switch 3) also in the ON position.

Note: When set in this state the oscilloscope is fixed as a TALKER and it cannot be remote-controlled.

The address switches of the objective GP-IB plotter connected to the bus line must be set in the LISTEN ONLY mode.

o LISTEN ONLY

Set all switches of the address section in the ON position but the T/L switch (switch 3) in the OFF position.

Note: When set in this state the instrument is fixed as a LISTENER and it cannot send out the measured data or any other information.

o Setting of Delimiters

Five types of delimiters as follows can be used.

- (1) EOI
- (2) CR
- (3) CR + EOI CR: Carriage Return
- (4) CR + LF LF: Line Feed
- (5) CR + LF + EOI EOI: End or Identify

Delimiters can be set with GP-IB switches ⑥③ and EOI command. When in transfer of binary data, however, EOI only can be used irrespective of switch setting.

Delimiter	GP-IB Switches ⑥③	EOI Command
EOI	Either setting	ONLY
CR	CR	OFF
CR + EOI	CR	ON
CR + LF	CR + LF	OFF
CR + LF + EIO	CR + LF	ON

Even when delimiter is other than "EOI ONLY", handshake terminates if EOI is given.

Notes: 1. When the oscilloscope is shipped from the factory, the delimiter switches are set for CR LF.

885735

2. When in transfer of binary data blocks, EOI alone is effective irrespective of delimiter switch setting.

Note: Refer to the notes for GP-IB switches.

3. The set states of GP-IB switches are read only once when turning on the oscilloscope. When power is continuously on, the address and delimiters do not change in response to change of switch settings. To change them, turn off power, change the switch settings, and then turn on the oscilloscope.
4. Other requirements comply with GP-IB (IEEE 488-1978) Standard.

(3) Device Functions

- o Transfer of Commands and Data
 - ① Remote control of panel setting
 - ② Transfer of setting data
 - ③ Transfer of measured data
 - ④ Transfer of waveform data

① Remote Control of Panel Setting

Front panel setting of the oscilloscope can be remote-controlled from an external controller through the GP-IB bus.

For example, to set the input coupling mode of CH1 to AC, send a character train of "CH1 COU AC" to the oscilloscope. The oscilloscope will decode the character train and will set the CH1 input coupling circuit to the AC mode.

By using "STEP" commands, setting is not made one by one but can be accomplished instantaneously.

885736

② Transfer of Setting Data

Data on setting of panel items of the oscilloscope can be sent to an external device, such as a host computer.

For example, when you want to read and send the set status of CH1, send a character train of "CH1?" to the oscilloscope. The oscilloscope will decode the character train and write the set status data of CH1 on the send buffer. Now designate the oscilloscope to be a talker, and a message representing the set status of CH1 will be sent. An example of message is shown below.

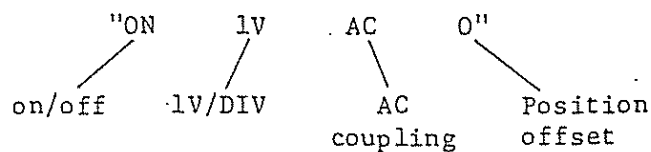

③ Transfer of Measured Data

Data measured with cursors, DVM and frequency counter are displayed on the CRT readout of the oscilloscope. This data can be transmitted to an external controller or other device.

For example, when you want to read and send the time interval measured with the cursors, send a character train of "CUR?" to the oscilloscope (provided that the cursors are in the ΔT mode). The oscilloscope will decode the character train and write the cursor mode and measured data on the send buffer. Now designate the oscilloscope to be a talker, and the data will be read and sent as follows:

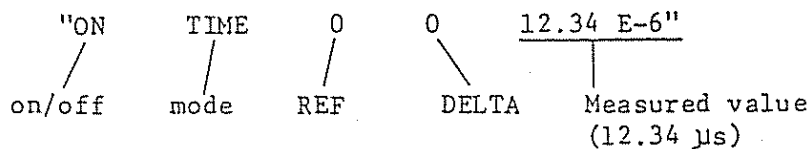

When you want to read and send the measured value alone, send a character train of "CUR DAT" to the oscilloscope. It will read and send the measured value alone as "12.34 E-6".

885737

④ Transfer of Waveform Data

The oscilloscope has four memory units, with memory capacity of 1024 points per unit. Data stored in these units can be transferred in ASCII or binary coded format to a computer for storing in a larger capacity, to a printer or a plotter for hardcopies, or to other devices for other purposes.

o Device Clear Function

As the oscilloscope receive a DEVICE CLEAR command, it clears its status bytes and send/receive buffers.

6.3.2 Command and Data Formats

To remote-control the oscilloscope with GP-IB, send data from the controller (host computer) in the following format:

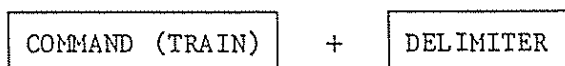

(1) Command Format

Each command should be a train of characters complying with ASCII Codes, and should be comprised of a header and arguments, and separators between them in a format as shown in the following example.

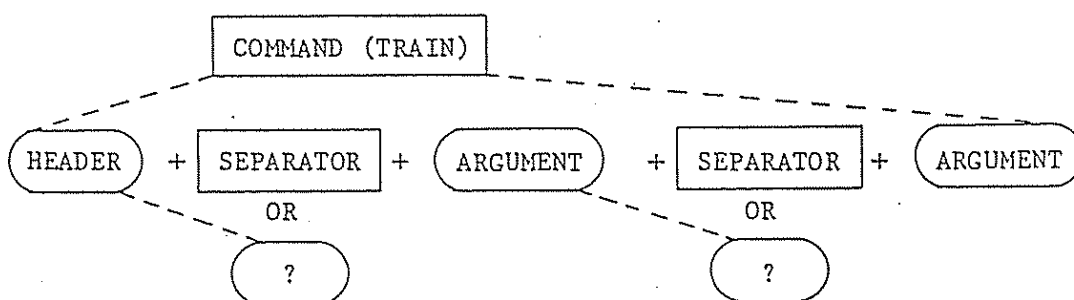

o Header

The header identifies the type of command, such as "CHANNEL 1" or "DVM".

885738

- Separators

A blank space code for one or more characters and semicolon ";" can be used as separators. A space code is used between header and argument or between two arguments.

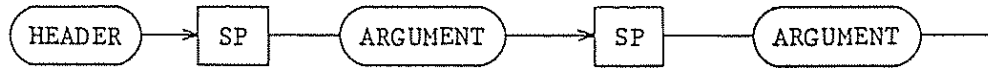

A semicolon can be used between two commands. When so specified, however, semicolons are effective only within the trains which follow the same header.

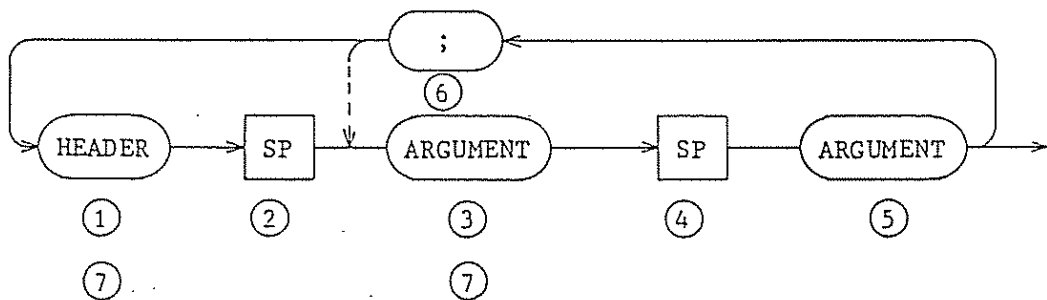

- Arguments

Two types of arguments can be used. One is a train of characters, such as "ON" or "AC". The other is a numerical data, such as "15" or "-20".

- Parameter "?"

This parameter is placed at the end of a command requesting to read and send. Note that "?" cannot be followed by another command or a separator ";".

(2) Waveform Data Formats and Blocks

Waveform data formats are selectable between ASCII codes and binary codes with "WAVE CODE" command as follows:

885739

o ASCII Codes

"NUMERAL , NUMERAL , NUMERAL , , NUMERAL " + DELIMITER

The range for the numerals is "000" to "255". All types of delimiters are effective.

o Binary Codes

"NUMERAL NUMERAL NUMERAL NUMERAL NUMERAL NUMERAL EOI "

The numerals are with eight bits for "0" to "11111111". For delimiters, EOI alone is effective.

Waveform data per channel (per memory unit) is stored on a 1k-word (1024 points) memory unit. Since memory unit is divided into eight blocks as illustrated below, part of the stored waveform data can be read and send by specifying block numbers.

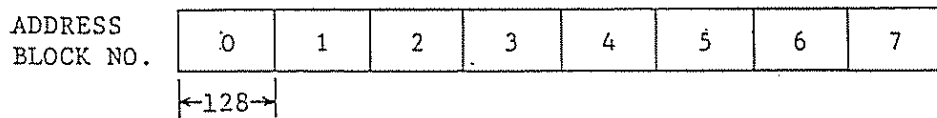

For example, to read and send data of from point 128 to point 511, specify start block 1 and end block 3 with the "WAVE" command.

(3) Delimiters

One of CR+LF(+EOI), CR(+EOI) and EOI can be used as delimiter. See page 6-9 "Setting of Delimiters".

(4) Abbreviations of Commands

As a general rule, commands including headers and arguments can be abbreviated into a string of three characters.

Examples: "ATRIGGER" → "ATR"
 "COUPLING" → "COU"
 "CHANNEL1" → "CH1"

Abbreviations of headers and arguments are shown being enclosed in parentheses in the table of commands.

(5) SRQ and Status Byte

The oscilloscope is allowed to originate a service request (SRQ) to send information on its internal events to the external controller, and displayed "SRQ" on the readout R2 of CRT. (See page 6-4 front panel). Events are identified by respective bits of a status byte, allowing the controller to identify the types of events.

When the oscilloscope is set to the local status, the SRQ becomes the ON state. To inhibit sending of service requests from the oscilloscope, give it a "SRQ OFF" command.

The relationships between the events and the corresponding bits of status byte are as shown below.

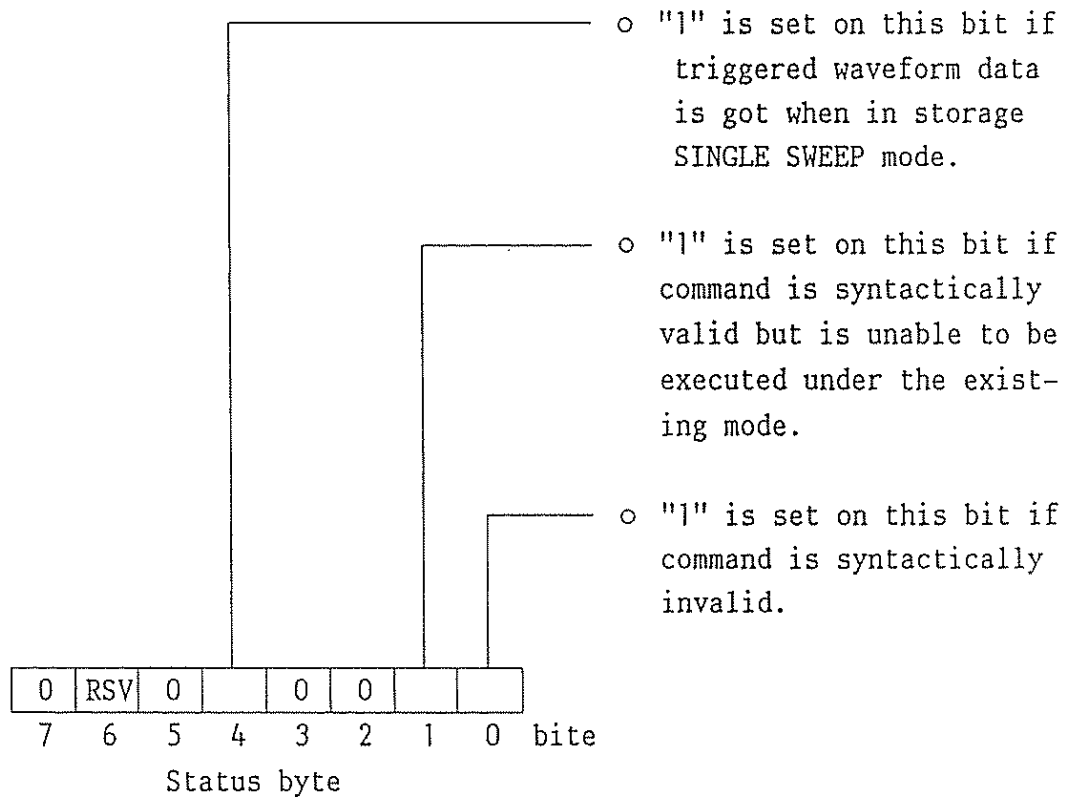

When power of the oscilloscope is turned on, "0" is set for all bits of the status byte.

885741

6.3.3 Data Send/Receive Sequence

The basic sequence of oscilloscope control by GP-IB is as described in this section.

(1) To Set Oscilloscope

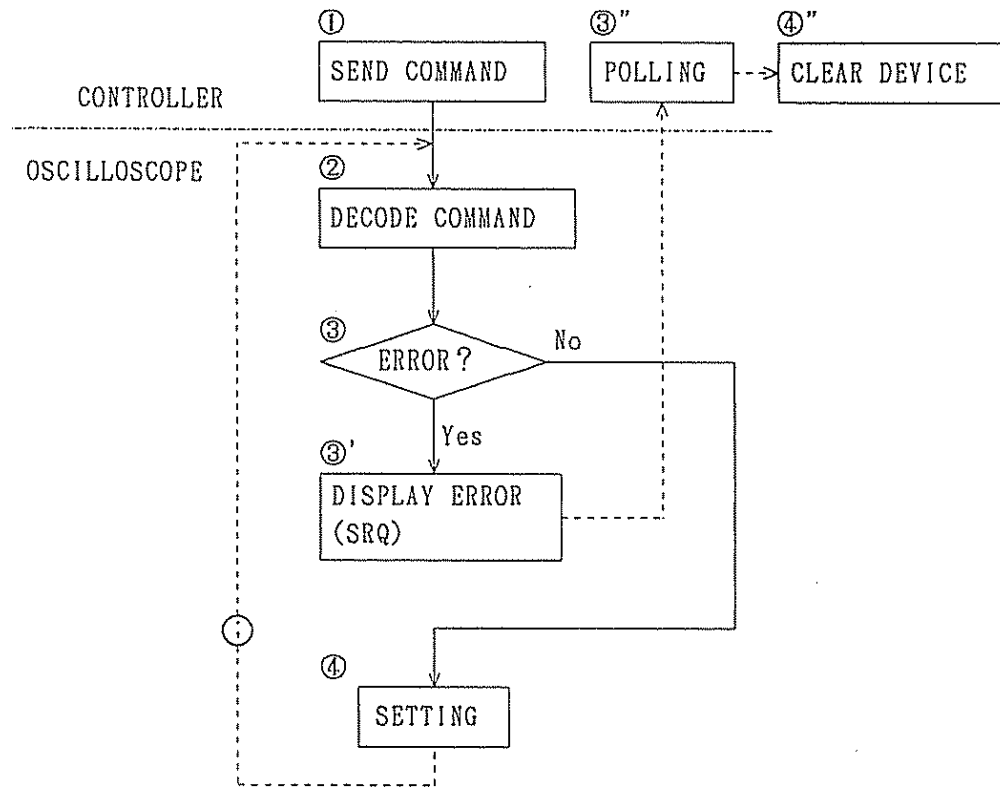

- ① Designate oscilloscope for listener and send command.
- ② Decode command stored in receive buffer of oscilloscope.
- ③ Check for errors.
- ③' Display errors, if any. (If SRQ function is enabled, send SRQ to controller.)
- ③'' In response to SRQ, perform serial polling and read status byte and then clear device.
- ④ Perform setting. If two or more commands are connected by ";", repeat ②, ③ and ④.

885742

(2) To Read Data

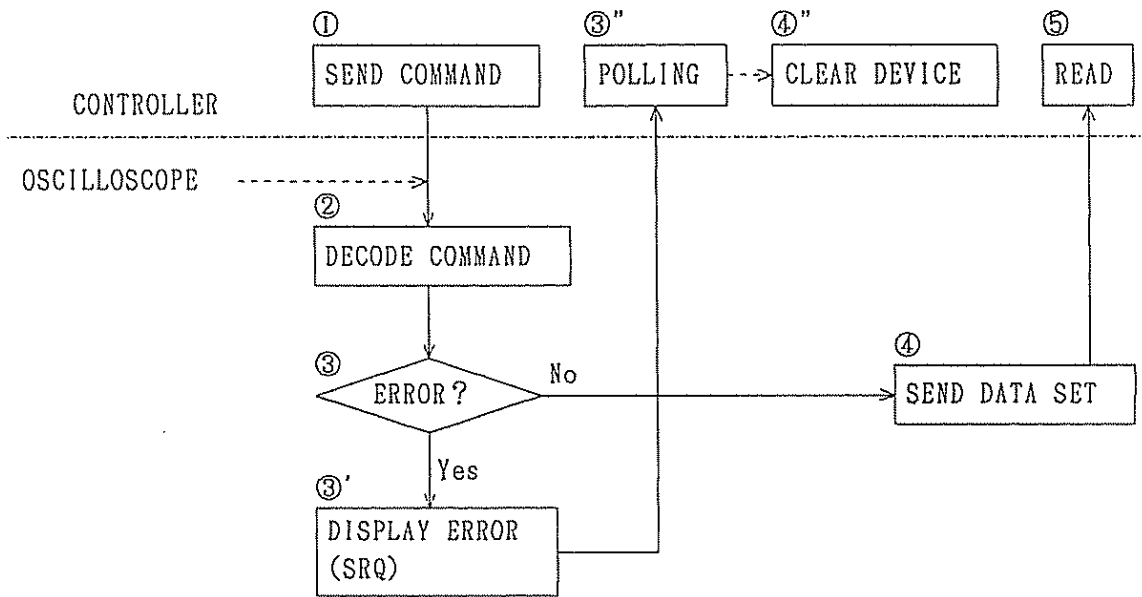

- ① Designate oscilloscope for listener and send command.
- ② Decode command stored in receive buffer of oscilloscope.
- ③ Check for errors and, if any, take necessary steps as in the case of (1).
- ④ Set specified data in send buffer.
- ⑤ Designate oscilloscope for talker to send data.

885743

6.4 Table of Commands

- o Items Indicated in Table

The table indicates individual commands which are used to control the oscilloscope. Each command is indicated together with its function and data to be sent when the oscilloscope is designated for a talker. Examples of writing programs referring to the table are given in this section.

(1) To Set the Oscilloscope

- o To set CH1 input coupling to AC

CHANNEL 1 (CH1)	ON OFF	Turn on CH1. Turn off CH1.
	<div style="border: 1px dashed black; display: inline-block; padding: 2px;">COUPLING (COU)</div> <div style="display: inline-block; vertical-align: middle; padding: 2px;"> <div style="border: 1px dashed black; display: inline-block; padding: 2px;">AC</div> DC GROUND </div>	Set CH1 input coupling to AC. Set CH1 input coupling to DC. Set CH1 input coupling to GND.

CHANNEL 1 + SPACE + COUPLING + SPACE + AC

Command is as

"CHANNEL1 COUPLING AC"

or abbreviated as "CH1 COU AC"

- o To Turn on CH2 and then invert it

Commands are written with abbreviations as follows:

"CH2 ON"

"CH2 INV ON"

The above two commands can be connected using a semicolon as follows:

"CH2 ON ; INV ON"

In this particular case, since there is internal specification of CH2, commands which can be connected are limited. When there are no specifications, other headers also can be connected.

- o To initialize CH2 and then turn it off

"INI ; CH2 OFF"

- (2) To read set range or measured data of oscilloscope

- o To read CH1 input coupling setting

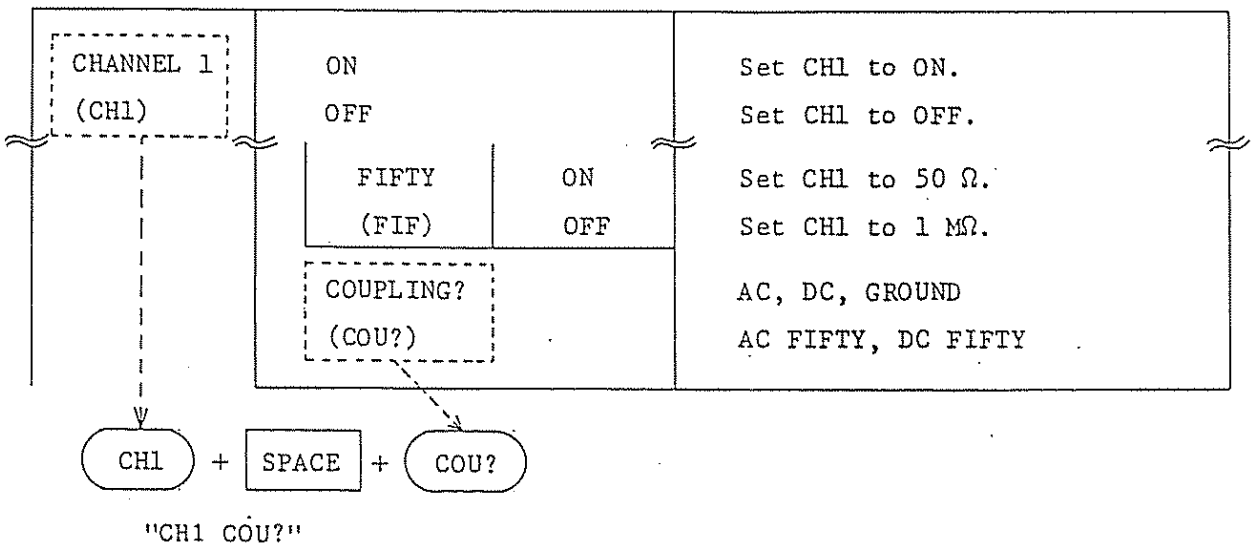

With this command, data on the current setting of CH1 input coupling of oscilloscope is written in the send buffer of oscilloscope. To read and send this data, designate the oscilloscope for a talker.

For PC-9801: INPUT @2; A\$ (Substitute character variable (NEC) A\$ with data.)

For HP-9816: ENTER 702; A\$ (Substitute character variable A\$ with data.)

Programs for the above can be written as follows:

```

PC-9801 (NEC)
10 PRINT @2; "CH1 COU?"
20 INPUT @2; A$
  
```

885745

HP-9816

10 OUTPUT 702; "CH1 COU?"

20 ENTER 702; A\$

30 END

Thus, setting data such as "AC" or "DC" can be read.

o To read setting of CH1

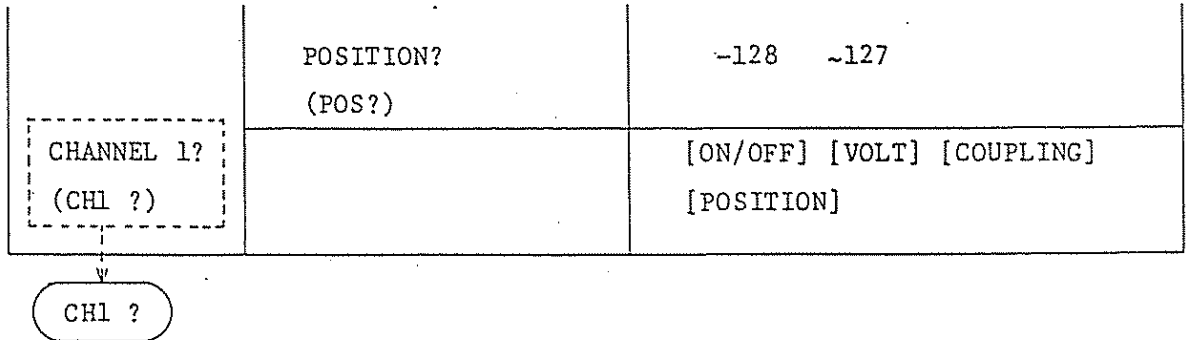

Example of set data as it is read:

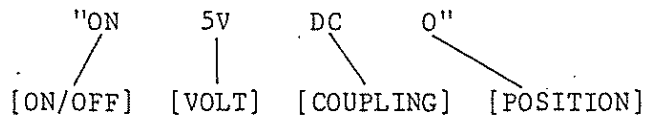

A blank space is placed between two set values.

885746

6.4.1 System Commands

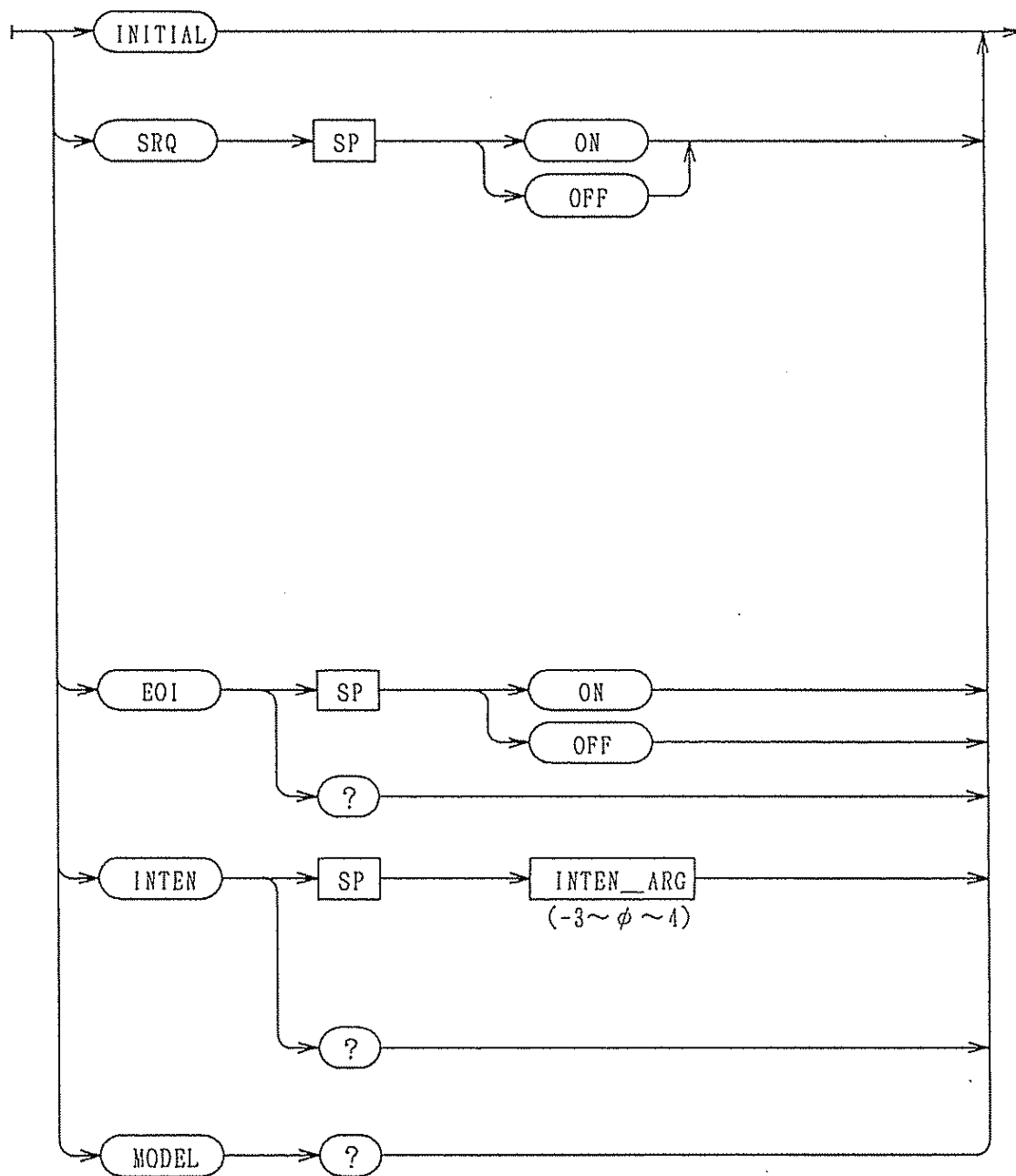

885747

Header	Argument	Action
INITIAL (INI)		Set to status identical with system reset.
SRQ SRQ?	ON OFF	Enable SRQ. Disable SQR. ON, OFF
EOI EOI?	ONLY (ONL) ON OFF	Limit delimiter to EOI only when send. Enable EOI when send. Disable EIO when send. ON, OFF, ONLY
INTEN (INT) INTEN? (INT?)	-3 ~4	Offset INTEN ②. -3(dark) ↔ 4(bright) -3, -2, ---- 3, 4
MODEL?		Model name COM7201E, COM7101E, COM7061A COM7200A, COM7100A, COM7060A

885748

6.4.2 Commands for Vertical Axis

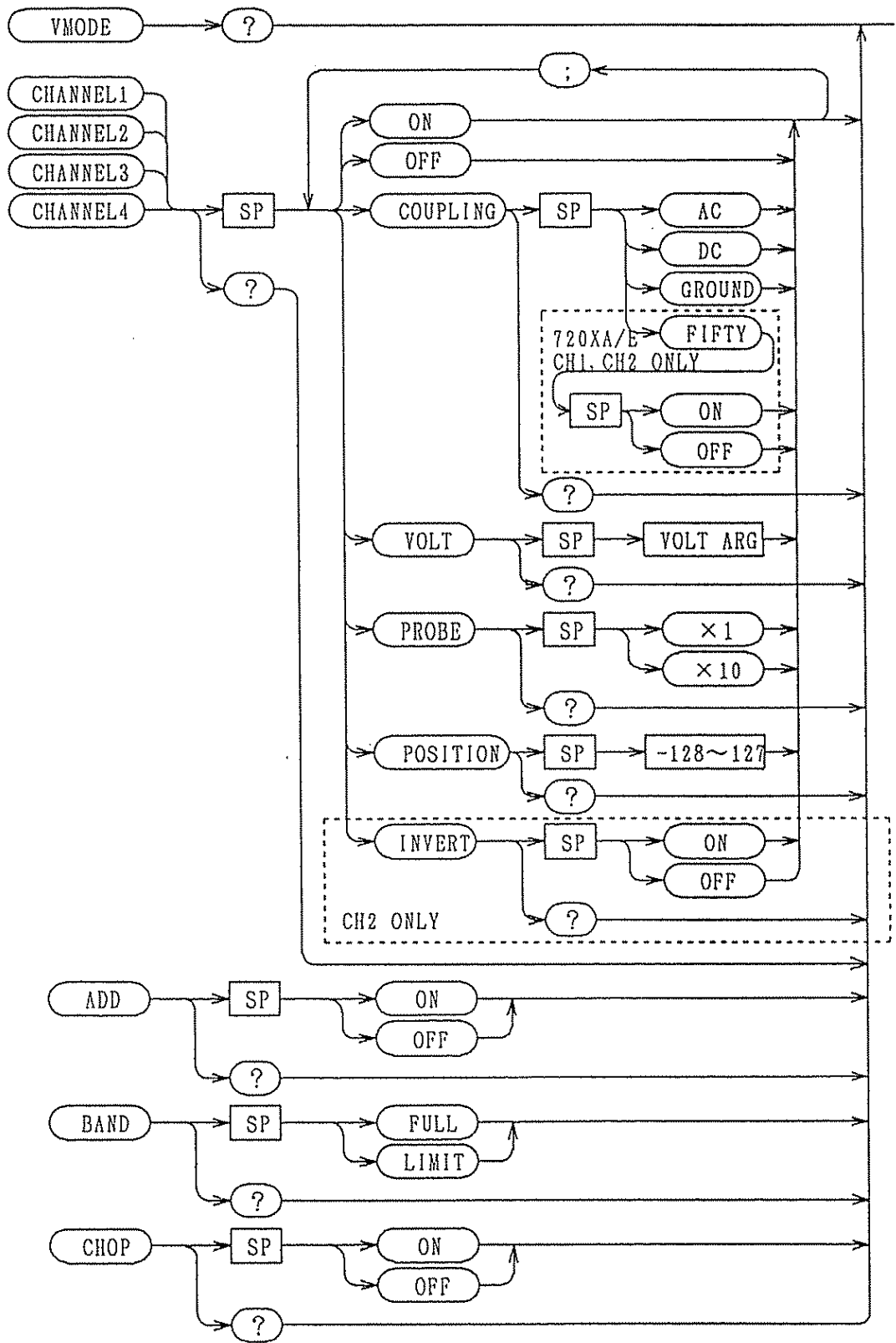

885749

Header	Argument		Action
VMODE? (VMO?)			VERT MODE such as CH1, CH2, ALT
CHANNEL1 (CH1)	ON		Turn on CH1.
	OFF		Turn off CH1.
	COUPLING (COU)	AC	Set CH1 input coupling to AC.
		DC	Set CH1 input coupling to DC.
	GROUND (GRO)		Set CH1 input coupling to GND.
	FIFTY (FIF)	ON	Set CH1 input coupling to 50Ω.
		OFF	Set CH1 input coupling to 1 MΩ. See Note 1.
	COUPLING? (COU?)		AC, DC, GROUND AC FIFTY, DC FIFTY
	VOLT (VOL)	5V	Set CH1 sensitivity to 5 V/DIV
		2V	Set CH1 sensitivity to 2 V/DIV
		1V	Set CH1 sensitivity to 1 V/DIV
.5V		Set CH1 sensitivity to 0.5V/DIV	
.2V		Set CH1 sensitivity to 0.2V/DIV	
.1V		Set CH1 sensitivity to 0.1V/DIV	
50MV		Set CH1 sensitivity to 50mV/DIV	
20MV		Set CH1 sensitivity to 20mV/DIV	
10MV		Set CH1 sensitivity to 10mV/DIV	
5MV		Set CH1 sensitivity to 5 mV/DIV	
2MV		Set CH1 sensitivity to 2 mV/DIV	
1MV	Set CH1 sensitivity to 1 mV/DIV		
VOLT? (VOL?)	5V ~ 1mV		
PROBE (PRO)	X1	Set CH1 probe and input sensitivity display to 1:1.	
	X10	Set CH1 probe and input sensitivity display to 10:1.	
PROBE? (PRO?)	x1, x10		
POSITION (POS)	-128	Set CH1 POSITION.	
	~ 127	See Note 2.	
POSITION? (POS?)	-128 ~ 0 ~ 127		
CHANNEL1? (CH1?)	[ON/OFF] [VOLT (x10) (UNCAL)] [COUPLING] [POSITION]		

Note 1: FIFTY is effective for COM7201E and COM7200A only.

Note 2: Be sure to set POSITION when in remote mode of operation.

885750

Header	Argument		Action	
CHANNEL2 (CH2)	ON		The same as that for CH1	
	OFF			
	COUPLING			
	VOLT			
CHANNEL2? (CH2?)	PROBE		The same as that for CH1	
	POSITION			
	INVERT (INV)	ON OFF		Enable CH2 INV. Disable CH2 INV.
	INVERT? (INV?)			ON, OFF
CHANNEL3 (CH3)	ON		Turn on CH3.	
	OFF		Turn off CH3.	
	COUPLING (COU)	AC DC GROUND (GRO)	Set input coupling to AC. Set input coupling to DC. Set input coupling to GND.	
	COUPLING? (COU?)		AC, DC, GROUND	
	VOLT (VOL)	0 or .5V 1 or .1V	Set CH3 sensitivity to 0.5V/DIV. Set CH3 sensitivity to 0.1V/DIV.	
	VOLT? (VOL?)		0.5V, 0.1V	
	PROBE (PRO)	X1 X10	Set CH1 probe and input sensitivity display to 1:1. Set CH1 probe and input sensitivity display to 10:1.	
	PROBE? (PRO?)		X1, X10	
	POSITION (POS)	-128 ~ 127	Set CH3 POSITION. See Note 1.	
	POSITION? (POS?)		-128 ~ 127	
CHANNEL3? (CH3?)			[ON/OFF] [VOLT] [COUPLING] [POSITION]	

Note 1: Be sure to set POSITION when in remote mode of operation.

885751

Header	Argument	Action
CHANNEL4 (CH4)	ON OFF COUPLING VOLT PROBE POSITION	} The same as that for CH3
CHANNEL4? (CH4?)		
ADD ADD?	ON OFF	Enable ADD. Disable ADD. ON, OFF
BAND (BAN)	FULL (FUL) LIMIT (LIM)	Without bandwidth limit. (BWL OFF) With bandwidth limit. (BLW ON)
BAND? (BAN?)		FULL, LIMIT
CHOP (CHO) CHOP? (CHO?)	ON OFF	Enable CHOP for multi-traces. Disable CHOP for multi-traces.(=ALT) ON, OFF

885752

6.4.3 Commands for Time Base (Horizontal Axis)

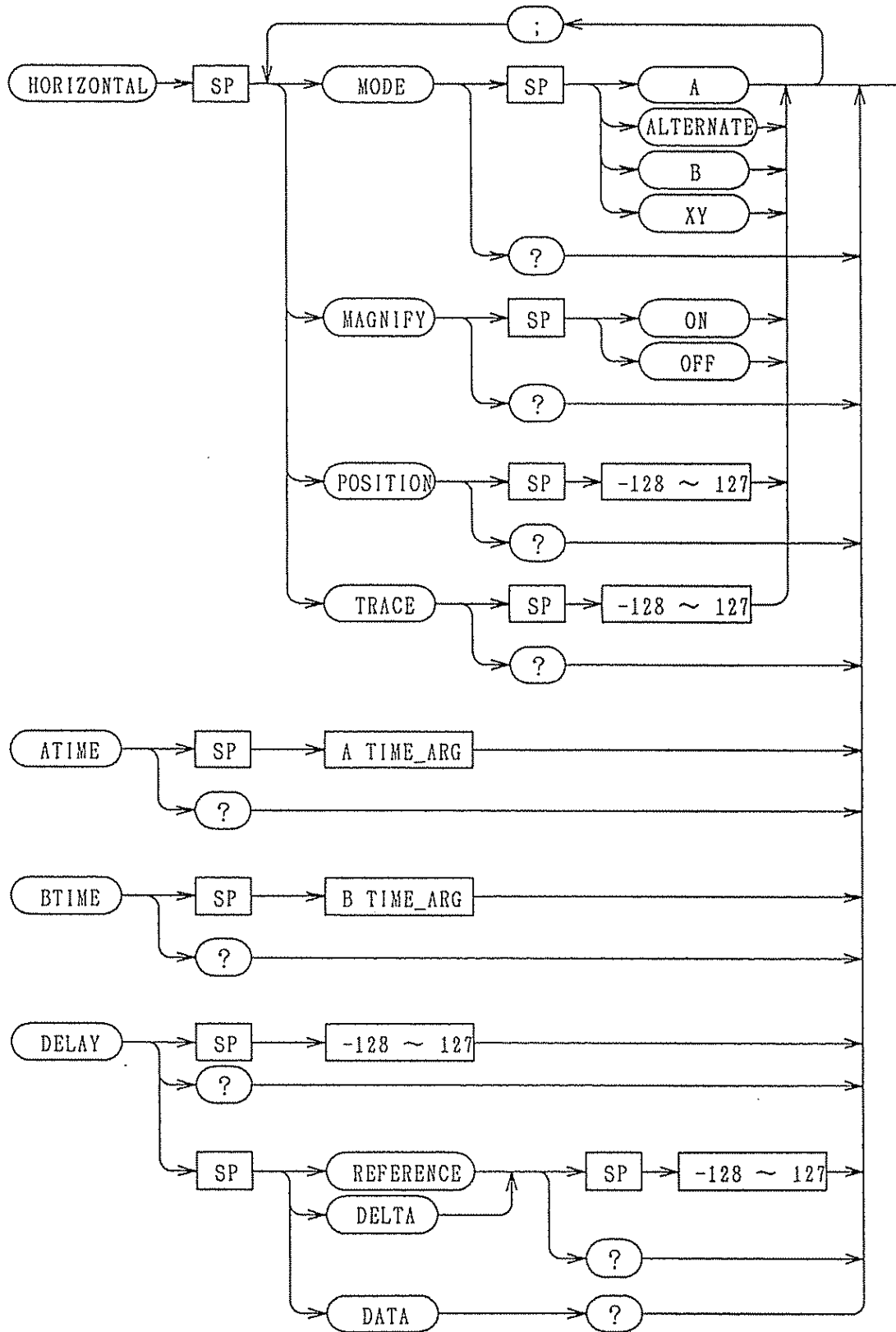

885743

Header	Argument		Action
HORIZONTAL (HOR)	MODE (MOD)	A	Set sweep mode to A.
		ALTERNATE (ALT)	Set sweep mode to ALT.
	MODE? (MOD?)	B	Set sweep mode to B.
		XY	Set to X-Y mode.
			A, ALT, B, XY
MAGNIFY (MAG)	ON	Enable x 10 MAG for horiz axis.	
	OFF	Disable x 10 MAG for horiz axis.	
MAGNIFY? (MAG?)		ON, OFF	
POSITION (POS)	-128 ~ 127	Set HORIZ POSITION.	
		-128 to 127	
POSITION? (POS?)			
TRACE (TRA)	-128 ~ 127	Set TRACE SEPARATION.	
		-128 to 127	
TRACE? (TRA?)			
HORIZONTAL? (HOR?)		[MODE] [MAG] [POS] [TRACE]	
HOLDOFF (HOL)	-127~128	Set HOLDOFF.	
HOLDOFF? (HOL?)		-127 to 128.	
ATIME (ATI)	Table 6-1	STORAGE 5s ~ 50ns, 20ns, 10ns	
ATIME? (ATI?)		REAL 0.5s ~ 50ns, 20ns, 10ns	
		(UNCAL)	
BTIME (BTI)	Table 6-1	See Note 1.	
BTIME? (BTI?)		0.5s ~ 50ns, 20ns, 10ns	

Note 1: B TIME/DIV cannot be set at a range slower than that of A TIME/DIV.

Table 6-1

Range	Argument	7060A	7100A	7200A	7061A	7101E	7201E	
Note	5s	5S				↑	↑	↑
	2s	2S						
	1s	1S						
.5s	.5S	↑	↑	↑				
.2s	.2S							
.1s	.1S							
50ms	50MS							
20ms	20MS							
10ms	10MS							
5ms	5MS							
2ms	2MS							
1ms	1MS							
.5ms	.5MS							
.2ms	.2MS							
.1ms	.1MS							
50μs	50US							
20μs	20US							
10μs	10US							
5μs	5US							
2μs	2US							
1μs	1US							
.5μs	.5US							
.2μs	.2US							
.1μs	.1US							
50ns	50NS	↓			↓			
20ns	20NS		↓			↓		
10ns	10NS			↓			↓	

Note: For storage mode only.

885755

Header	Argument		Action
DELAY (DEL)	MODE (MOD)	DELAY (DEL)	Set to DELAY mode.
		TIME (TIM)	Set to double delay ΔT mode.
		PERTIME (PER)	Set to double delay $1/\Delta T$ mode.
	MODE? (MOD?)		DELAY, TIME, PERTIME
	-128 ~ 127		Set DELAY POSITION.
	REFERENCE (REF)	-128 ~ 127	Set DELAY (REF) POSITION.
	REFERENCE? (REF?)		0 ~ 4095
DELTA (DEL)	-128 ~ 127	Set DELAY(DELTA) POSITION.	
		DELTA? (DEL?)	0 ~ 4095
DATA? (DAT?)		Value of DELAY ΔT or $1/\Delta T$. See Note 1.	
DELAY? (DEL?)		[MODE] (REF) (DELTA) [DATA]	

Note 1: When SWEEP VARIABLE (7) is enabled, unit of measure is DIV.

6.4.4 Commands for Triggering

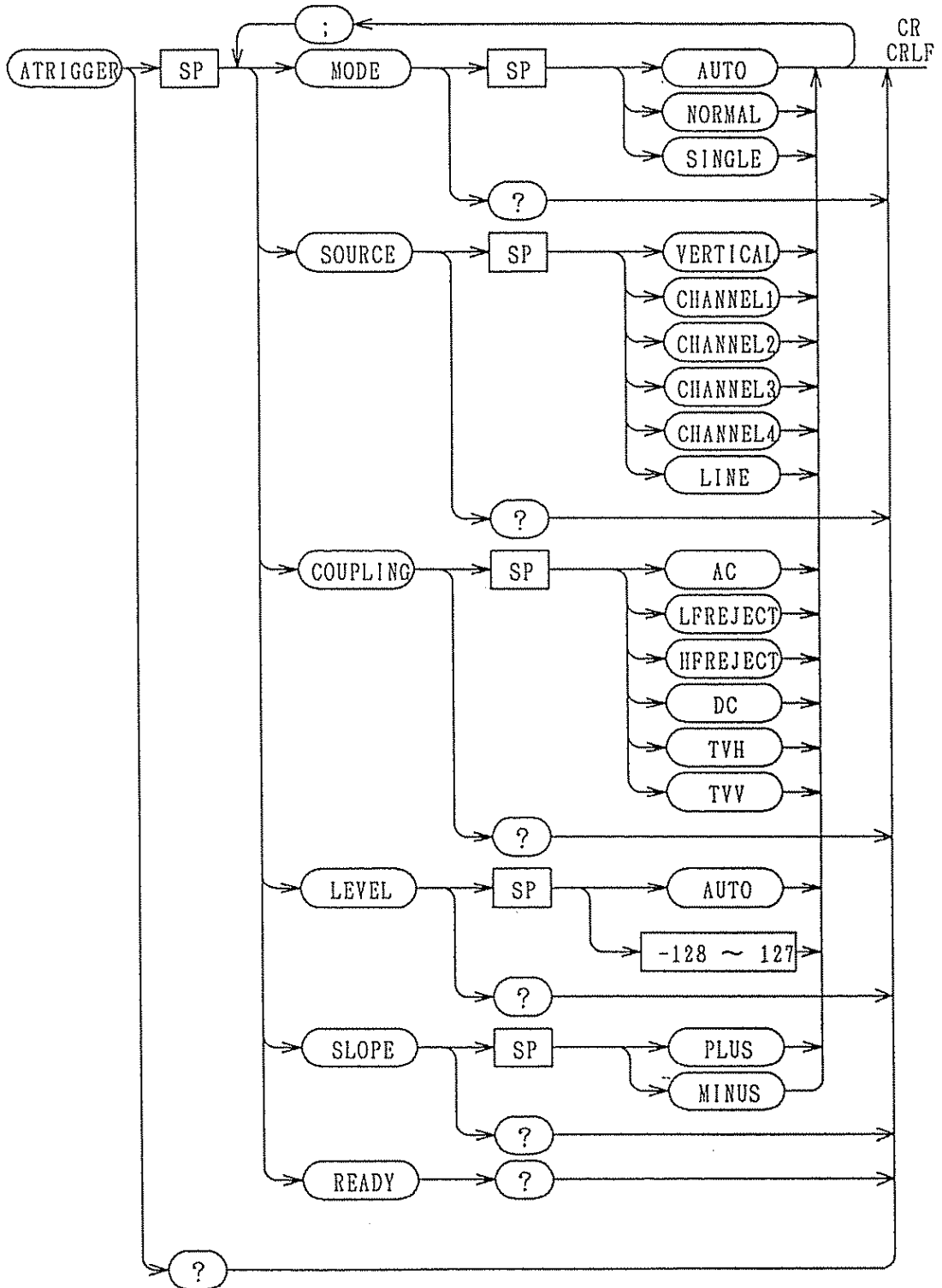

885757

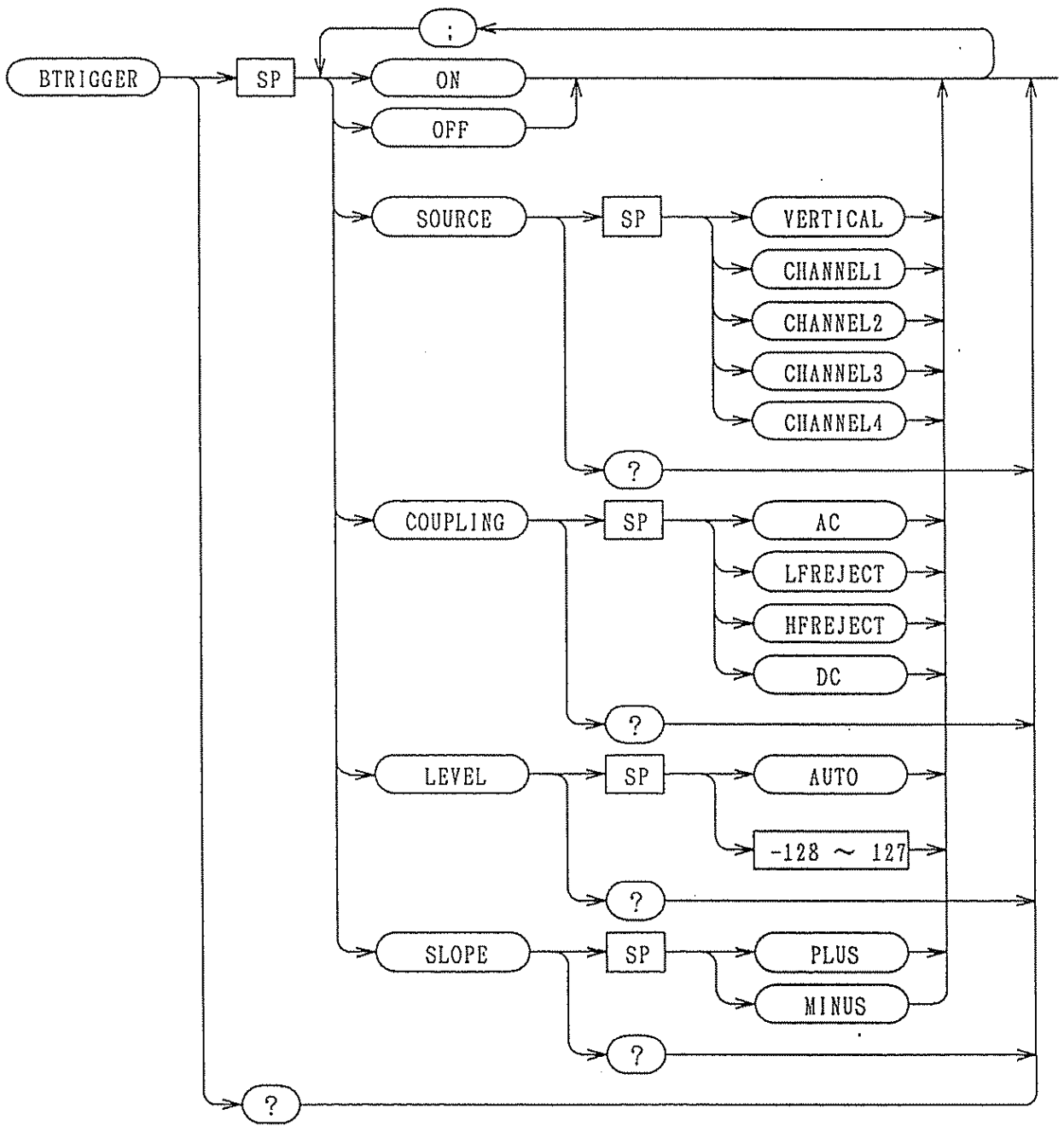

885758

Header	Argument		Action
ATRIGGER (ATR)	MODE (MOD)	AUTO (AUT)	Set A trigger to AUTO mode.
		NORMAL (NOR)	Set A trigger to NORMAL mode.
		SINGLE (SIN)	Set A trigger to SINGLE mode.
	MODE? (MOD?)		AUTO, NORMAL, SINGLE
	SOURCE (SOU)	VERTICAL (VER)	Set A trigger source to VERT.
		CHANNEL1 (CH1)	Set A trigger source to CH1.
CHANNEL2 (CH2)		Set A trigger source to CH2.	
CHANNEL3 (CH3)		Set A trigger source to CH3.	
CHANNEL4 (CH4)		Set A trigger source to CH4.	
LINE (LIN)	Set A trigger source to LINE		
SOURCE? (SOU?)		VERT, CH1, CH2, CH3, CH4 LINE	
COUPLING (COU) (LFR) (HFR)	AC	Set A trig-in coupling to AC.	
	LFREJECT	Set A trig-in coupling to LF-REJ.	
	HFREJECT	Set A trig-in coupling to HF-REJ.	
	DC	Set A trig-in coupling to DC.	
	TVH	Set A trig-in coupling to TVH.	
TVV	Set A trig-in coupling to TVV.		
COUPLING? (COU?)		AC, LFR, HFR, DC, TVH, TVV	
LEVEL (LEV)	-128~127	Set A trigger level.	
	AUTO	Set A trigger level to AUTO.	
LEVEL? (LEV?)		-128 ~ 127, AUTO	

885759

ATRIGGER? (ATR?)	SLOPE (SLO)	PLUS (PLU) MINUS (MIN)	Set A trigger slope to "+" Set A trigger slope to "-"
	SLOPE? (SLO?)		PLUS, MINUS
			[MODE] [SOURCE] [COUPLING] [LEVEL] [SLOPE]
BTRIGGER (BTR)	ON OFF		Turn on B trigger. Turn off B trigger.
	SOURCE (SOU)	VERTICAL (VER) CHANNEL1 (CH1) CHANNEL2 (CH2) CHANNEL3 (CH3) CHANNEL4 (CH4)	Set B trigger source to VERT. Set B trigger source to CH1. Set B trigger source to CH2. Set B trigger source to CH3. Set B trigger source to CH4.
	SOURCE? (SOU?)		VERT, CH1, CH2, CH3, CH4
	COUPLING (COU)	AC LFREJECT (LFR) HFREJECT (HFR) DC	Set B trig-in coupling to AC. Set B trig-in coupling to LFR. Set B trig-in coupling to HFR. Set B trig-in coupling to DC.
	COUPLING? (COU?)		AC, LFR, HFR, DC
	LEVEL (LEV) LEVEL? (LEV?)	-128 ~ 127 AUTO	Set B trigger level. Set B trigger level to AUTO. -128 ~ 127, AUTO
	SLOPE (SLO) SLOPE? (SLO?)	PLUS (PLU) MINUS (MIN)	Set B trigger slope to "+". Set B trigger slope to "-". PLUS, MINUS
BTRIGGER? (BTR?)		[ON/OFF] [SOURCE] [COUPLING] [LEVEL] [SLOPE]	

885760

6.4.5 Commands for Cursors

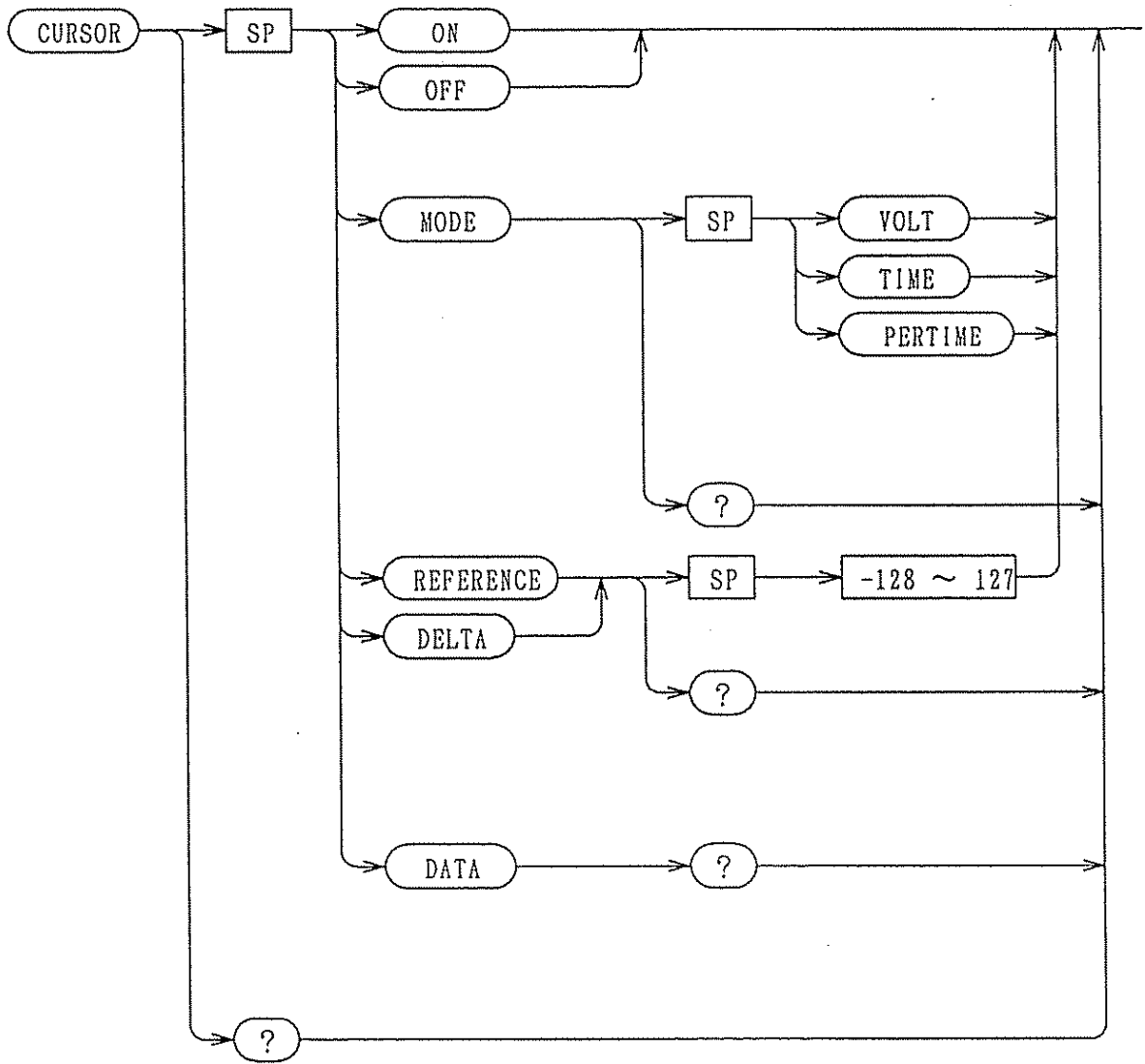

885761

Header	Argument	Action	
CURSOR (CUR)	ON	Turn on cursor.	
	OFF	Turn off cursor.	
	MODE (MOD)	VOLT (VOL) TIME (TIM) PERTIME (PER)	Set cursor mode to ΔV . Set cursor mode to ΔT . Set cursor mode to $1/\Delta T$.
	MODE? (MOD?)		VOLT, TIME, PERTIME
	REFERENCE (REF)	-128 ~ 127	Set CURSOR (REF) POSITION.
	REFERENCE? (REF?)		0 ~ 4095
	DELTA (DEL)	-128 ~ 127	Set CURSOR (DELTA) POSITION.
DELTA? (DEL?)		0 ~ 4095	
DATA? (DAT?)		Value measured with cursors.	
CURSOR? (CUR?)		[ON/OFF] [MODE] [REFERENCE] [DELTA] [DATA]	

6.4.6 Commands for DVM and Counter

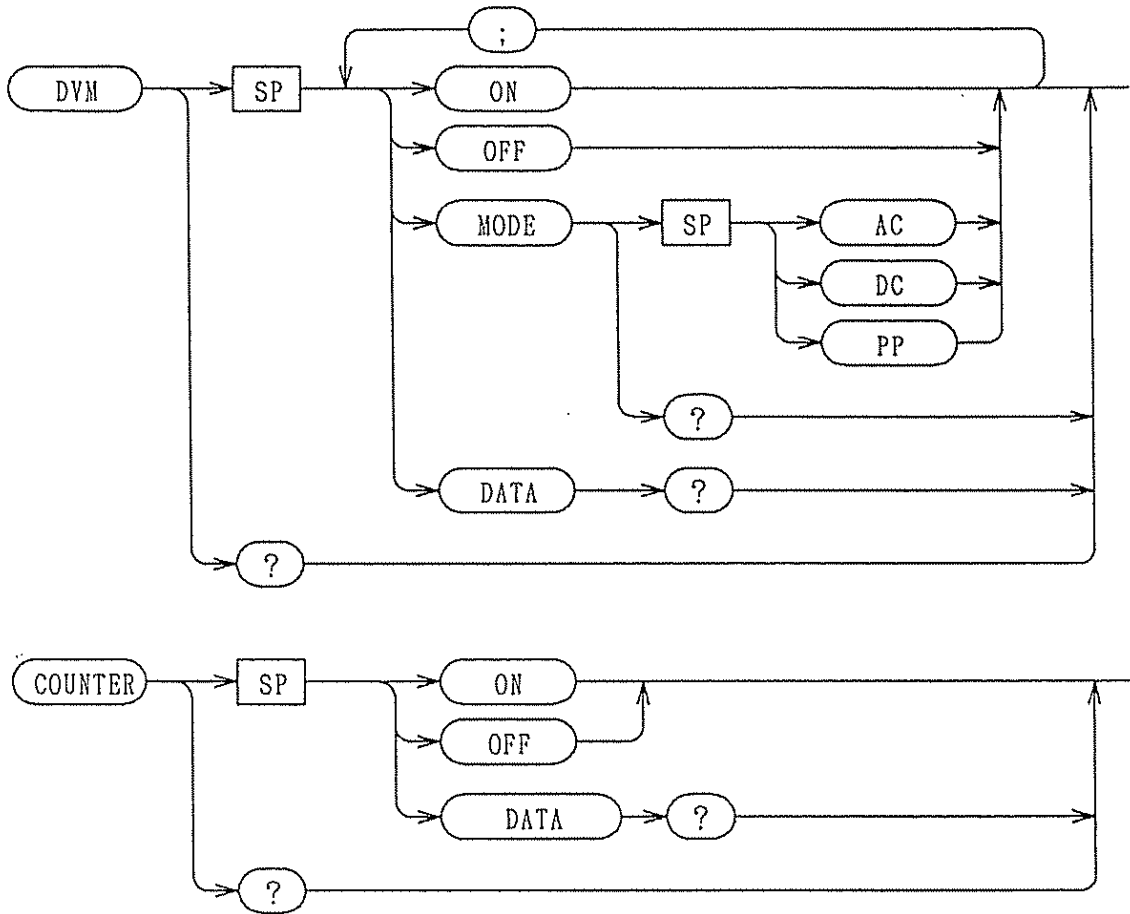

Header	Argument	Action	
DVM	ON	Turn on DVM.	
	OFF	Turn off DVM.	
	MODE	AC	Set DVM mode to AC.
	(MOD)	DC	Set DVM mode to DC.
		PP	Set DVM mode to p-p.
	MODE?	AC, DC, PP	
	(MOD?)		
	DATA?	Value measured with DVM.	
	(DAT?)		
DVM?		[ON/OFF] [MODE] [DATA]	
COUNTER (COU)	ON	Turn on counter.	
	OFF	Turn off counter.	
	DATA?	Value measured with counter.	
	(DAT?)		
COUNTER?		[ON/OFF] [DATA]	
(COU?)			

885763

6.4.7 Commands for Step Control

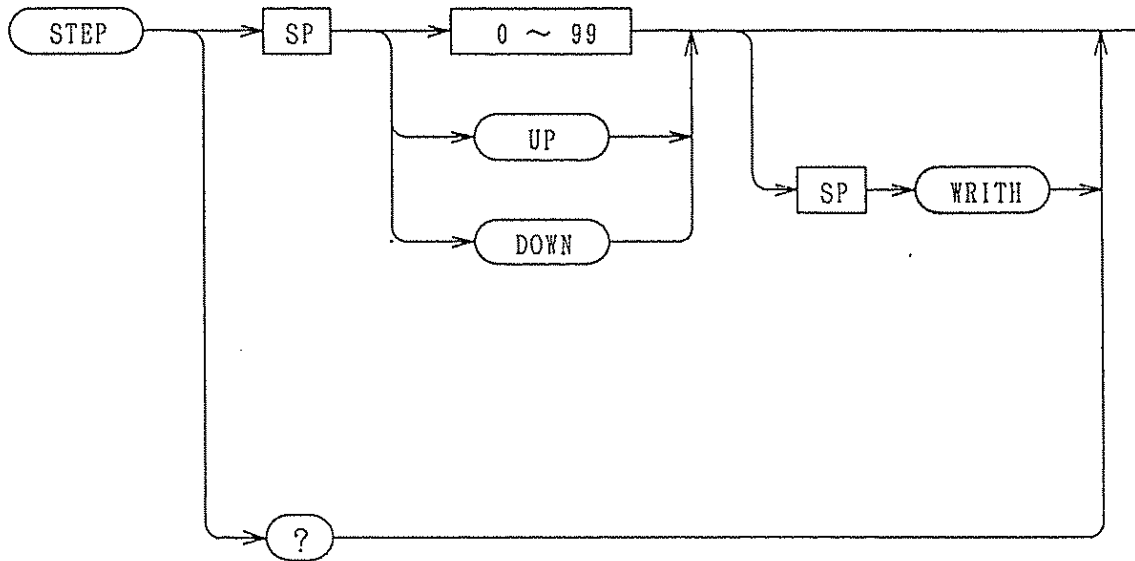

Header	Argument	Action
STEP (STE)	0~99	Read data on step memory.
	WRITE (WRI)	Write data on step memory.
	UP	Increment step address by 1.
	WRITE (WRI)	Increment step address by 1 and then write data on memory.
DOWN (DOW)		Decrement step address by 1.
	WRITE (WRI)	Decrement step address by 1 and then write data on memory.
STEP? (STE?)		Current step address 0 ~ 99

6.4.8 Commands for Storage

(1) Commands which always operate when in storage mode

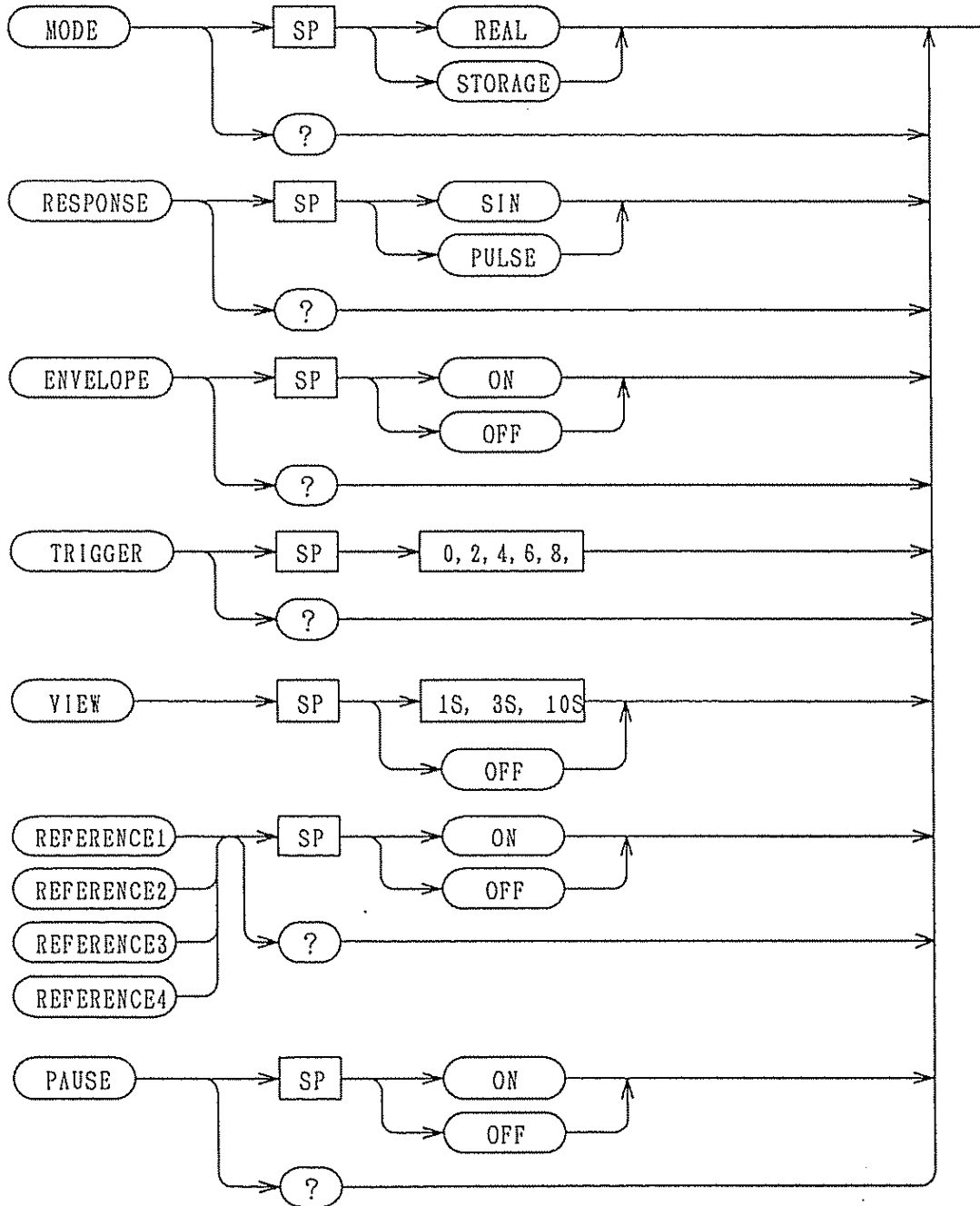

885735

Header	Argument	Action
MODE (MOD)	REAL (REA)	Set to realtime mode.
	STORAGE (STO)	Set to stostorage mode.
MODE? (MOD?)		REAL, STORAGE
RESPONSE (RES)	SIN	Set to sine interpolation.
	PULSE (PUL)	Set to pulse interpolation.
RESPONSE? (RES?)		SIN, PULSE
TRIGGER (TRI)	0, 2, 4, 6, 8	Set triggerrig point. Unit in DIV.
TRIGGER? (TRI?)		0, 2, 4, 6, 8
VIEW (VIE)	OFF, 1S, 3S, 10S	Set viewtime. Unit in sec.
VIEW? (VIE?)		OFF, 1S, 3S, 10S
REFERENCE1 (REF1)	ON	Turn on REF1.
	OFF	Turn off REF1.
REFERENCE1? (REF1?)		ON, OFF [ON/OFF] [VOLT(UNCAL)] [COUPLING] [TIME/DIV]
REFERENCE2 (REF2)	ON	Turn on REF2.
	OFF	Turn off REF2.
REFERENCE2? (REF2?)		ON, OFF
REFERENCE3 (REF3)	ON	Turn on REF3.
	OFF	Turn off REF3.
REFERENCE3 (REF3?)		ON, OFF
REFERENCE4 (REF4)	ON	Turn on REF4.
	OFF	Turn off REF4.
REFERENCE4? (REF4?)		ON, OFF

Header	Argument	Action
PAUSE	ON	Turn on PAUSE.
(PAU)	OFF	Turn off PAUSE.
PAUSE?		ON, OFF
(PAU?)		

2) Commands for 50ms/DIV - 10µs/DIV

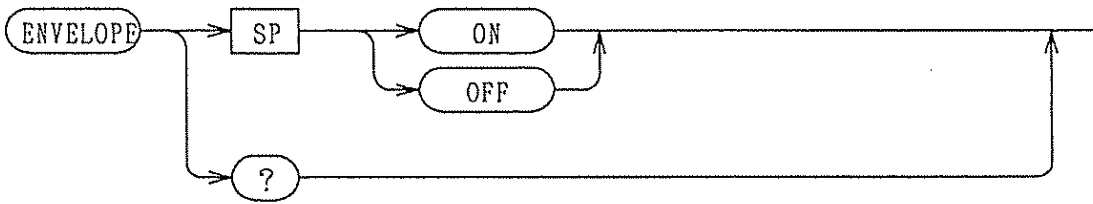

Header	Argument	Action
ENVELOPE	ON	Turn on ENVELOPE mode.
(ENV)	OFF	Turn off ENVELOPE mode.
ENVELOPE?		ON, OFF
(ENV?)		

3) Commands which are effective only when in PAUSE ON

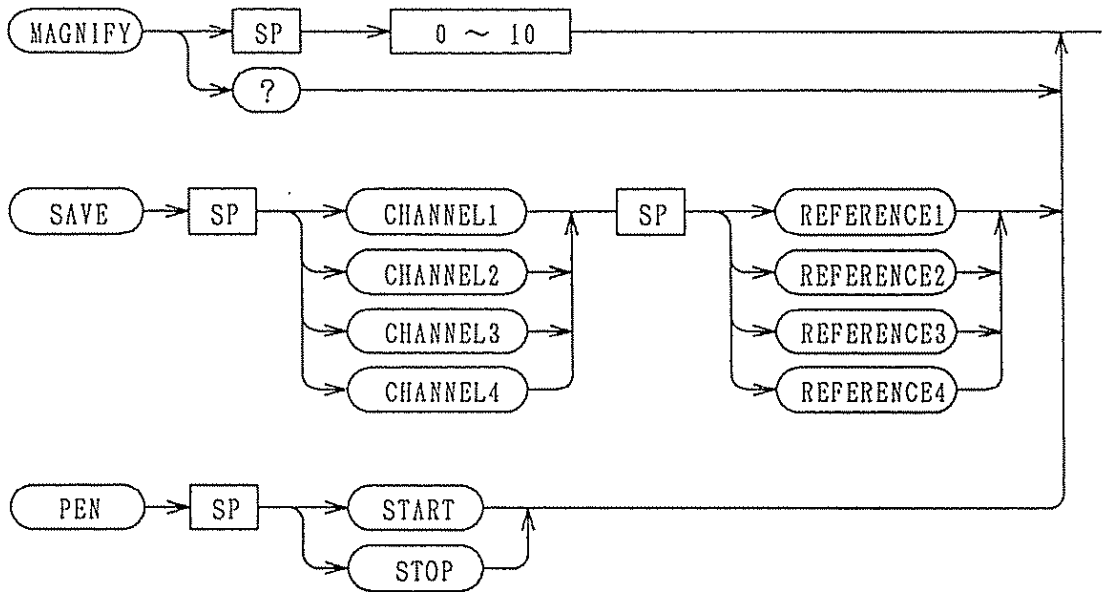

Header	Argument		Action
MAGNIFY (MAG)	0, 1, ..., 10		Set magnification point. Unit in DIV 0, 1, ..., 10
MAGNIFY? (MAG?)			
SAVE (SAV)	CHANNEL1 (CH1) CHANNEL2 (CH2) CHANNEL3 (CH3) CHANNEL4 (CH4)	REFERENCE1 (REF1) REFERENCE2 (REF2) REFERENCE3 (REF3) REFERENCE4 (REF4)	Save waveform data in reference memory. Error message is sent if specified channel is not ON. If specified reference memory is OFF, it is automatically turned ON.
PEN	START (STA) STOP (STO)		Start PEN output. Stop PEN output.

(4) Commands for send/receive of waveform data

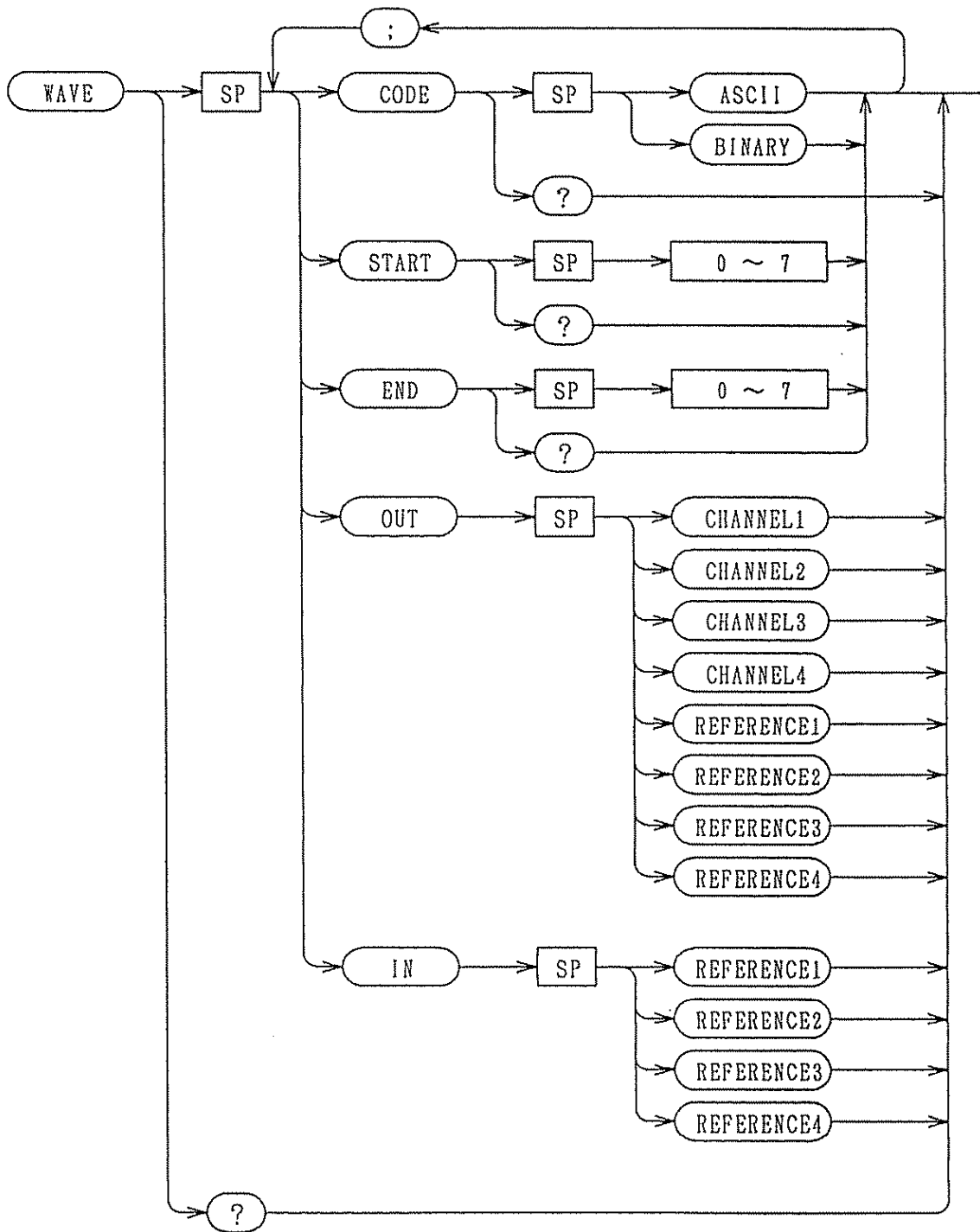

885769

Header	Argument		Action	
WAVE (WAV)	CODE (COD)	ASCII (ASC)	Use ASCII codes for waveform data transfer. (See Note.)	
		BINARY (BIN)	Use binary codes for waveform data transfer. (See Note.)	
	CODE? (COD?)		ASCII, BINARY	
	START (STA)	0~7	START? (STA?)	Set starting block of waveform data.
	END	0~7	END?	Set ending block of waveform data.
	OUT	CHANNEL1 (CH1)	Send waveform data of CH1.	
		CHANNEL2 (CH2)	Send waveform data of CH2.	
		CHANNEL3 (CH3)	Send waveform data of CH3.	
CHANNEL4 (CH4)		Send waveform data of CH4.		
REFERENCE1 (REF1)		Send waveform data of REF1.		
REFERENCE2 (REF2)		Send waveform data of REF2.		
REFERENCE3 (REF3)		Send waveform data of REF3.		
REFERENCE4 (REF4)		Send waveform data of REF4.		
IN	REFERENCE1 (REF1)	Receive waveform data onto REF1.		
	REFERENCE2 (REF2)	Receive waveform data onto REF2.		
	REFERENCE3 (REF3)	Receive waveform data onto REF3.		
	REFERENCE4 (REF4)	Receive waveform data onto REF4.		
WAVE? (WAV?)			[CODE] [START] [END]	

Note: "WAVE IN" is for binary codes only.

6.5 Output for GP-IB Plotter

With the conventional oscilloscopes, no hardcopies of the waveform data displayed on the CRT screen can be obtained unless a rather troublesome method with a camera or a computer system is employed. The COM7XX1A/E Series Oscilloscope delivers an output of the waveform data displayed on the CRT, allowing you to directly obtain hardcopies by operating it in the storage mode and employing a GP-IB plotter (HP-GL compatible type). When in the plotter output mode, the starting point of plotting by the plotter conforms with the left-end point of the CRT graticule, the $\times 10$ MAG function is ignored, and no information is delivered for the VIEW TIME " and pause functions.

(1) Connecting the Instruments

Connect a GP-IB plotter or plotters directly to the COM7XX1A/E Oscilloscope. (No other instruments are needed.)

(2) Setting the Instrument

COM7XX1A/E: Before turning on power of the oscilloscope, set the GP-IB switches ⑥③ to the TALK ONLY mode. (See page 6-8 TALK ONLY.)

Plotter: Set the plotter to the LISTEN ONLY mode.

Note: If the oscilloscope has already acquired a waveform data with its GP-IB switches ⑥③ set at a normal address (0 - 30) and turning on its power, save the waveform data in the reference memory, turn off power of oscilloscope once, set the GP-IB switch ⑥③ to the TALK ONLY mode, and then turn on power again.

(3) Operating Procedure

- (a) Set the oscilloscope to the STORAGE mode and display on its CRT screen the CRT readout data and waveform data to be hardcopied.

885771

- (b) If the center lines of the graticule are not required to be hardcopied, turn off the SCALE ⑤ (graticule illumination control). The hardcopied data will be as shown in the left hand one of the illustrations.

If the CRT readout data (data indicated with characters) is not required to be hardcopied, turn off the READOUT ⑤. The hardcopied data will be as shown in the left hand one of the illustrations.

- (c) 1. Keeping pressed the 2nd FUNCTION KEY ④③, press the "(PLT 1)" key of the HORIZ MODE ③⑤. The hardcopy will be drawn with a scale factor of double of that of the CRT graticule.
2. Keeping pressed the 2nd FUNCTION KEY ④③, press the "(PLT 2)" key of the HORIZ MODE ③⑤. The hardcopy will be drawn with a scale factor identical with that of the CRT graticule.

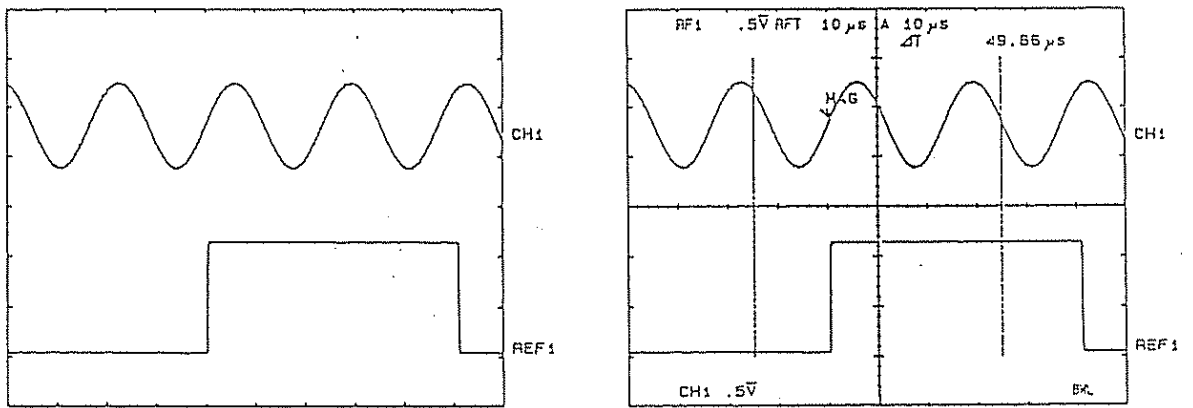

- (d) To abort hardcopying in progress, press the 2nd FUNCTION KEY.

6.6 Programming Examples

6.6.1 Examples of Programming for PC-9801 Computer of NEC

(1) Initial Setting

Set an address for the PC-9801 (personal computer used as controller) and that for the oscilloscope with GP-IB switches (63). For this programming example, set them as shown in the following table.

	Address	Delimiter
PC-9801	0	CR LF
COM7×××A/E	2	CR LF

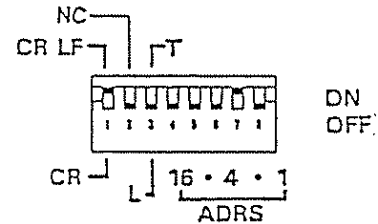

(2) Programming Example for Panel Control

This programming example is for controlling the oscilloscope from the computer keyboard to the functions the same with those made with the oscilloscope panel controls. In response to the prompter "COMMAND?" displayed on the computer, enter commands (characters for the required functions) from the keyboard. Of the Execution Example of Program (1.1), enter the underlined characters. Symbol ↵ denotes the RETURN key (line feed key).

Program (1.1)

```

10 DIM COMMAND$(100), DAT$(100)
20 ISET IFC : ISET REN
30 CMD DELIM=0
40 INPUT "COMMAND" ; COMMAND$
50 PRINT @2 ; COMMAND$
55 FOR I=0 TO 300 : NEXT I
57 WBYTE &H14;
60 GOTO 40

```

(Comments)

```

10 Declare array and secure data area.
20 Initialize interface and set REN to true.
30 Specify CR and LF for delimiters.
40 Receive command entered from keyboard.

```

885773

- 50 Send command received from keyboard.
- 55 Timer
- 57 Send device clear command for in case of error.
(This statement may be deleted if not required.)
- 60 Go to statement 40 to receive next command.

Remarks: If an invalid command is given, an error message "GPIB ERR" is displayed on the oscilloscope and an SRQ is generated. To cope with this, there are two methods: One is to release the SRQ by stopping the program once and running it again so that the interface is initialized. The other is to use a command (such as statement 57) irrespective of occurrence of errors. If a device clear command is received when the processing for the command sent by statement 50 is in progress, the processing is aborted and completed. In order to wait until the processing is complete, statement 55 "Timer" should be inserted.

Execution Example of Program (1.1)

- ① To select CH1 input coupling:

COMMAND?	<u>CHANNEL1 COUPLING AC</u> ↵
Abbreviation	<u>CH1 COU AC</u> ↵

- ② To select storage mode:

COMMAND?	<u>MODE STORAGE</u> ↵
Abbreviation	<u>MOD STO</u> ↵

- ③ To set to PAUSE:

COMMAND?	<u>PAUSE ON</u> ↵
Abbreviation	<u>PAU ON</u> ↵

- ④ To set to SAVE:

COMMAND?	<u>SAVE CHANNEL1 REFERENCE1</u> ↵
Abbreviation	<u>SAV CH1 REF1</u> ↵

Of other panels also, the functions of the controls can be dictated through the computer keyboard. That is, all commands except "WAVE IN" and "WAVE OUT" can be given through the computer keyboard.

(3) Programming Examples to Read Panel Setting and Measured Values

Examples of programs to read the panel setting values and measured values, and to reset the system automatically when an invalid command is given are described below.

Program (1.2)

```
10 DIM COMMAND$(100), DAT$(100)
20 ISET IFC : ISET REN
30 CMD DELIM=0
40 INPUT "COMMAND" ; COMMAND$
50 PRINT @2 ; COMMAND$
60 INPUT @2 ; DAT$
70 PRINT TAB(9) ; DAT$
80 GOTO 40
```

(Comments)

```
10 Declare array and secure data area.
20 Initialize interface and set REN to true.
30 Specify CR and LF for delimiters.
40 Receive command entered from keyboard.
50 Send command received from keyboard.
60 Receive setting value or other data.
70 Display the received setting value or other data.
80 Go to statement 40 to receive next command.
```

If an invalid command is given in the above program, it will stop at statement 60 and an SRQ is generated. Therefore, a program to release the SRQ must be added.

Program (1.3)

```
5 SRQ OFF
10 DIM COMMAND$(100), DAT$(100)
20 ISET IFC : ISET REN
30 CMD DELIM=0
32 ON SRQ GOSUB *SRQSUB
34 SRQ ON
40 INPUT "COMMAND" ; COMMAND$
50 PRINT @2 ; COMMAND$
55 FOR I=0 TO 300 : NEXT I
```

885775

```

60 INPUT @2 ; DAT$
70 PRINT TAB(9) ; DAT$
80 GOTO 40
100 '
110 *SRQSUB
120 SRQ OFF
130 POLL 2, STB
140 WBYTE &H14 ;
150 PRINT "SRQ / GP-IB ERROR"
160 SRQ ON
170 RETURN 40

```

(Comments)

```

5 Disable once SRQ reception in order to cope with such state that
  SRQ has already been generated when starting program.
10 The same with that of Program (1.2)
20 The same with that of Program (1.2)
30 The same with that of Program (1.2)
32 Specify processing routine to be employed when SRQ is
  generated.
34 Enable SRQ reception.
40 The same with that of Program (1.2)
50 The same with that of Program (1.2)
55 If an invalid command is sent, an error is caused and an SRQ is
  generated. Allow a period for generating the SRQ.
60 The same with that of Program (1.2)
70 The same with that of Program (1.2)
80 The same with that of Program (1.2)
100
110 SRQ processing routine.
120 Disable SRQ reception.
130 Perform serial polling.
140 Clear device.
150 Display error message.
160 Enable SRQ reception again.
170 Go to statement 40 and receive next command.

```

Execution Example of Program (1.3)

① Setting state of CH1

COMMAND?	<u>CHANNEL1 COUPLING?</u> ↵
Abbreviation	<u>CH1 COU?</u> ↵
Display ex.	DC

② Setting state of MODE

COMMAND?	<u>MODE?</u> ↵
Abbreviation	<u>MOD?</u> ↵
Display ex.	REAL

③ To set to ATIME

COMMAND?	<u>ATIME?</u> ↵
Abbreviation	<u>ATI?</u> ↵
Display ex.	10US

Of other panels also, the functions of the controls can be dictated through the computer keyboard. The underlined items of the above commands are those to be manually entered through the keyboard. That is, all commands except "WAVE IN" and "WAVE OUT" can be given through the computer keyboard.

(4) Programming Example to Set Panel Controls and to Read Setting Values

This program is a modified one of Program (1.3) so that setting of panel controls also can be done.

Program(1.4)

```
5      SRQ OFF
10     DIM COMMAND$(100), DAT$(100)
20     ISET IFC : ISET REN
30     CMD DELIM=0
32     ON SRQ GOSUB *SRQSUB
34     SRQ ON
40     INPUT "COMMAND" ; COMMAND$
50     PRINT @2 ; COMMAND$
55     FOR I=0 TO 300 : NEXT I
57     IF RIGHT$(COMMAND$, 1) <> "?" THEN 40
60     INPUT @2 ; DAT$
```

885777

```

70 PRINT TAB(9) ; DAT$
80 GOTO 40
100 '
110 *SRQSUB
120 SRQ OFF
130 POLL 2, STB
140 FOR I=0 TO 300 : NEXT I
150 WBYTE &H14 ;
160 PRINT "SRQ / GP-IB ERROR"
170 SRQ ON
180 RETURN 40

```

(Comments)

```

5 The same with that of Program (1.3)
10 The same with that of Program (1.3)
20 The same with that of Program (1.3)
30 The same with that of Program (1.3)
32 The same with that of Program (1.3)
34 The same with that of Program (1.3)
40 The same with that of Program (1.3)
50 The same with that of Program (1.3)
55 The same with that of Program (1.3)
57 If the command is not of the type which calls for reading of
    setting value or other data, go to statement 40 and wait for
    the next command.
60 The same with that of Program (1.3)
70 The same with that of Program (1.3)
80 The same with that of Program (1.3)
100
110 SRQ processing routine
120 The same with that of Program (1.3)
130 The same with that of Program (1.3)
140 The same with that of Program (1.3)
150 The same with that of Program (1.3)
160 The same with that of Program (1.3)
170 The same with that of Program (1.3)
180 The same with that of Program (1.3)

```

885778

(5) Examples of Commands for Control of Cursors and Reading of Measured Values

Examples of commands for control of cursors and reading of values measured with cursors, using the program (1.4) are given below.

① "CURSOR MODE" command, with program of (1.4)

COMMAND?	<u>CURSOR MODE VOLT</u> ↵
Abbreviation	<u>CUR MOD VOL</u> ↵

② "CURSOR DELTA" command, with program of (1.4)

COMMAND?	<u>CURSOR DELTA 50</u> ↵
Abbreviation	<u>CUR DEL 50</u> ↵

Note: Even when in the remote mode, the cursors can be vernier-controlled with the READOUT control.

③ Moving the cursors with the READOUT control, read the measured value. "CURSOR DATA?" command, with program of (1.4)

COMMAND?	<u>CURSOR DATA?</u> ↵
Abbreviation	<u>CUR DAT?</u> ↵
Display ex.	12.34 E-3

The underlined items of the above commands are those to be manually entered through the keyboard. For "↵", press the RETURN key.

(6) Examples of Commands for Control of DVM and Counter, and Reading of Measured Values

Examples of commands for control of the DVM and counter and reading of the measured values, using the program (1.4) are given below.

When in the remote mode with GP-IB, the DVM and the counter can be ON/OFF-controlled independently.

① "DVM MODE" command, with program of (1.4)

COMMAND?	<u>DVM MODE AC</u> ↵
Abbreviation	<u>DVM MOD AC</u> ↵

- ② "DVM DATA?" command, with program of (1.4)
- | | |
|--------------|-------------------|
| COMMAND?" | <u>DVM DATA?↵</u> |
| Abbreviation | <u>DVM DAT?↵</u> |
| Display ex. | 12.34 E-3 |
- ③ "COUNTER" command, with program of (1.4)
- | | |
|--------------|--------------------|
| COMMAND? | <u>COUNTER ON↵</u> |
| Abbreviation | <u>COU ON↵</u> |
- ④ "COUNTER DATA?" command, with program of (1.4)
- | | |
|--------------|-----------------------|
| COMMAND? | <u>COUNTER DATA?↵</u> |
| Abbreviation | <u>COU DAT?↵</u> |
| Display ex. | 12.34 E-6 |

The underlined items of the above commands are those to be manually entered through the keyboard. For "↵", press the RETURN key.

(7) Examples of Programs for Transfer of Waveform Data

This section introduces programs to send waveform data acquired in the storage mode to the host computer or other devices. The programs (1.1) through (1.4) are not usable for this purpose. Examples of programs for individual cases are shown below.

① Program to send data (binary) from oscilloscope to PC-9801 of NEC

Program (1.5)

```

100 DIM WAVDAT%(1023)
110 ISET IFC : ISET REN
120 CMD DELIM=0
130 PRINT @2 ; "MOD STO"
140 PRINT @2 ; "PAU ON"
150 PRINT @2 ; "WAV COD BIN"
160 PRINT @2 ; "WAV OUT CH1"
170 WBYTE 64+2, 32+0;
180 FOR LOOP=0 TO 1023
190 RBYTE ; WAVDAT%(LOOP)
200 NEXT LOOP

```

(Comments)

- 100 Declare array and secure data area.
- 110 Initialize interface and set REN to true.
- 120 Specify CR and LF for delimiters.
- 130 Set to STORAGE mode.
- 140 Turn on PAUSE so that waveform data can be sent.
- 150 Specify binary for waveform data codes.
- 160 Request CH1 waveform output.
- 170 Designate oscilloscope for talker and designate controller (computer) for listener. If addresses differ, modify this statement.
- 180 Prepare number of loops corresponding to number of data items.
- 190 Enter transferred data item into array variable WAVDAT%, sequentially.
- 200 Go to statement 180 until all loops are over.

Remarks: Block Transfor

It also is possible to send only a part of the above waveform data, by dividing the total addresses into eight blocks by using the "WAVE START" and "WAVE END" commands, and by sending data in the unit of block. The relationships between data addresses and blocks are as shown in the following.

Block	0	Addresses	0 ~ 127
Block	1	Addresses	128 ~ 255
Block	2	Addresses	256 ~ 383
Block	3	Addresses	384 ~ 511
Block	4	Addresses	512 ~ 639
Block	5	Addresses	640 ~ 767
Block	6	Addresses	768 ~ 895
Block	7	Addresses	896 ~ 1023

For block transfer, add statements as shown in the following example to Program (1.5) and make the number of loops of statement 180 conform with the number of data items.

Example: To read block 0 only

```
152 PRINT @2; "WAV STA 0"  
154 PRINT @2; "WAV END 0"
```

885781

In the above example, the number of data items is 128 and variable I of statement 180 assumes values 0 - 127.

② Program to send data (binary) from PC-9801 to oscilloscope

For the above program it is assumed that the preceding program of (1.6) has been executed and waveform data has already been stored in WAVDAT%(LOOP).

Program (1.6)

```
210 PRINT @2; "MOD STO"
220 PRINT @2; "REF1 ON"
230 PRINT @2; "PAU ON"
240 PRINT @2; "WAV COD BIN"
250 PRINT @2; "WAV IN REF1"
260 WBYTE 64+0, 32+2;
270 FOR LOOP=0 TO 1022
280 WBYTE; WAVDAT%(LOOP)
290 NEXT LOOP
300 WBYTE; WAVDAT%(1023)@
```

(Comments)

```
210 Set to STORE mode.
220 Turn on REFERENCE 1.
230 Turn on PAUSE to transfer waveform data.
240 Specify binary for waveform data codes.
250 Specify waveform data entry to REFERENCE 1.
260 Designate oscilloscope for listener and designate controller
      (computer) for talker.
      If addresses differ, modify this statement.
270 Prepare number of loops corresponding to number of data items-
      1.
280 Transfer data sequentially from array variable WAVDAT%.
290 Go to statement 280 until all loops are over.
300 Deliver final data item and EOI.
```

As in the case of ①, part of waveform data can be sent by using "WAVE START" and "WAVE END" commands.

885782

(8) Step Control

This section introduces examples of programs for panel settings making use of step memory (0 - 99). In this simple method, programmable control for up to 100 types of oscilloscope panel settings can be realized.

① To write panel setting on step memory

Program (1.7)

```
10 ISET IFC
20 CMD DELIM=0
30 STEPNO=0
40 IRESET REN
50 PRINT "STEP NO = " ; STEPNO
60 INPUT "PANEL SET & HIT RETURN", A$
70 COMMAND$="STE"+STR$(STEPNO)+"WRI"
80 ISET REN
90 PRINT @2; COMMAND$
100 IF STEPNO<99 THEN STEPNO=STEPNO+1
110 FOR I=0 TO 1000 : NEXT I
120 GOTO 40
```

(Comments)

```
10 Initialize interface and set REN to true.
20 Specify CR and LF for delimiters.
30 Initialize step number.
40 Set to LOCAL mode.
50 Display step number.
60 Set panel and wait for pressing of RETURN key.
70 Connect commands.
80 Set REN to true.
90 Write panel setting on step memory.
100 Increment step by 1.
110 Timer
120 Go to statement 40 and repeat setting.
```

(Note)

When in the LOCAL mode, even though you may adjust the vertical position, horizontal position, trigger level, holdoff, and trace separation controls, the adjustment data cannot be written on the

memory. If you want to write the adjustment data on the step memory, adjust the controls in the REMOTE mode and then directly execute the step command without returning to the LOCAL mode.

② To read panel setting data on step memory

Program (1.8)

```
10 ISET IFC : ISET REN
20 CMD DELIM=0
30 INPUT "STEP No = " ; STEPNO
40 IF STEPNO<0 OR STEPNO>99 TEHN 30
50 COMMAND$="STE " +STR$(STEPNO)
60 PRINT @2; COMMAND$
70 GOTO 30
```

(Comments)

```
10 Initialize interface and set REN to true.
20 Specify CR and LF for delimiters.
30 Enter step number.
40 Check step number.
50 Connect commands.
60 Read panel setting data which is written on step memory.
70 Go to statement 30 and repeat setting.
```

(9) Example of SRQ Processing

If the oscilloscope is set in a storage SINGLE TRIGGER STANDBY status, storing of waveform data in memory automatically starts as the triggering is effected. When storing in all addresses is over, an SRQ is generated. Thus, completion of data acquisition can be known by receiving the SRQ signal. An example of reception program is shown in the following.

Program (1.9)

```
10 SRQ OFF
20 ISET IFC : ISET REN
30 CMD DELIM=0
40 ON SRQ GOSUB *ACQEND
50 PRINT @2; "MOD STO"
60 PRINT @2 ; "PAU OFF"
```

885784

```
70 PRINT @2 ; "ATR MOD SIN"
80 SRQ ON
90 GOTO 90
100 '
110 *ACQEND
120 SRQ OFF
130 POLL 2, STB
140 PRINT "ACQUISITION END !"
150 RETURN 70
```

(Comments)

```
10 Disable once SRQ reception in order to cope with such state
    that SRQ has already been generated when starting program.
20 Initialize interface and set REN to true.
30 Specify CR and LF for delimiters.
40 Specify processing routine to be followed when SRQ is
    generated.
50 Set to STORE mode.
60 Release PAUSE.
70 Set to SINGLE TRIGGER STANDBY status.
80 Enable SRQ reception.
90 Wait for SRQ generation.
100
110 SRQ processing routine.
120 Disable SRQ reception.
130 Perform serial polling.
140 Display acquisition completion message.
150 Go to statement 70 and set again to SINGLE TRIGGER STANDBY
    status.
```

6.6.2 Examples of Programming for Model 9826 Computer of HP

(1) Initial Setting

Set an address for the Model 9826 (personal computer used as controller) and that for the oscilloscope with GP-IB switches ⑥③.

For this programming example, set them as shown in the following table.

	Address	Delimiter
MODEL 9826	0	CR LF
COM7xxxA/E	2	CR LF

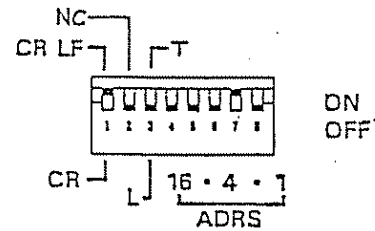

(2) Programming Example for Panel Control

This programming example is for controlling the oscilloscope from the computer keyboard to the functions the same with those made with the oscilloscope panel controls. In response to the prompter "COMMAND?" displayed on the computer, enter commands (characters for the required functions) from the keyboard. Of the Execution Example of Program (2.1), enter the underlined characters. Symbol ↵ denotes the ENTER key (line feed key).

Program (2.1)

```

10 DIM Command$ [100]
20 ABORT 7
30 REMOTE 7
40 ASSIGN @Com TO 702
50 INPUT "COMMAND ?",Command$
60 OUTPUT @Com;Command$
61 WAIT 1
62 CLEAR @Com
70 GOTO 50
80 END

```

(Comments)

```

10 Declare array and secure data area.
20 Initialize interface.
30 Set REN to true.
40 Assign attribute.

```

- 50 Receive command entered from keyboard.
- 60 Send command received from keyboard.
- 61 Timer
- 62 Send device clear command for in case of error.
(This statement may be deleted if not required.)
- 70 Go to statement 40 to receive next command.

Remarks: If an invalid command is given, an error message "GPIB ERR" is displayed on the oscilloscope and an SRQ is generated. To cope with this, there are two methods: One is to release the SRQ by stopping the program once and running it again so that the interface is initialized. The other is to use a command (such as statement 62) irrespective of occurrence of errors. If a device clear command is received when the processing for the command sent by statement 60 is in progress, the processing is aborted and completed. In order to wait until the processing is complete, statement 61 "Timer" should be inserted.

Execution Example of Program (2.1)

- ① To select CH1 input coupling:

COMMAND?	<u>CHANNEL1 COUPLING AC</u> ↵
Abbreviation	<u>CH1 COU AC</u> ↵
- ② To select storage mode:

COMMAND?	<u>MODE STORAGE</u> ↵
Abbreviation	<u>MOD STO</u> ↵
- ③ To set to PAUSE:

COMMAND?	<u>PAUSE ON</u> ↵
Abbreviation	<u>PAU ON</u> ↵
- ④ To set to SAVE:

COMMAND?	<u>SAVE CHANNEL1 REFERENCE1</u> ↵
Abbreviation	<u>SAV CH1 REF1</u> ↵

Of other panels also, the functions of the controls can be dictated through the computer keyboard. That is, all commands except "WAVE IN" and "WAVE OUT" can be given through the computer keyboard.

885787

(3) Programming Examples to Read Panel Setting and Measured Values

Examples of programs to read the panel setting values and measured values, and to reset the system automatically when an invalid command is given are described below.

Program (2.2)

```
10 DIM Command$[100],Dat$[100]
20 ABORT 7
30 REMOTE 7
40 ASSIGN @Com TO 702
50 INPUT "COMMAND ? ",Command$
60 OUTPUT @Com;Command$
70 ENTER @Com;Dat$
80 PRINT Dat$
90 GOTO 50
100 END
```

(Comments)

```
10 Declare array and secure data area.
20 Initialize interface.
30 Set REN to true.
40 Assign attribute.
50 Receive command entered from keyboard.
60 Send command received from keyboard.
70 Receive setting value or other data.
80 Display the received setting value or other data.
90 Go to statement 50 to receive next command.
```

If an invalid command is given in the above program, it will stop at statement 70 and an SRQ is generated. Therefore, a program to release the SRQ must be added.

Program (2.3)

```
10 DIM Command$[100]
20 ABORT 7
30 REMOTE 7
40 ASSIGN @Com TO 702
41 ON INTR 7 GOTO Srq_rou
42 ENABLE INTR 7;2
50 INPUT "COMMAND ?",Command$
```

885788

```

60 OUTPUT @Com;Command$
61 WAIT .5
70 ENTER @Com;Dat$
80 PRINT Dat$
90 GOTO 50
100 !
110 Srq_rou: !
120             DISABLE INTR 7
130             Stb=SPOLL(@Com)
140             WAIT .5
150             CLEAR @Com
160             PRINT "SRQ/GP-IB ERROR"
170             ENABLE INTR 7;2
180             GOTO 50
190 END

```

(Comments)

```

10 The same with that of Program (2.2)
20 The same with that of Program (2.2)
30 The same with that of Program (2.2)
40 The same with that of Program (2.2)
41 Specify processing routine to be employed when SRQ is
    generated.
42 Enable SRQ reception.
50 The same with that of Program (2.2)
60 The same with that of Program (2.2)
61 If an invalid command is sent, an error is caused and an SRQ is
    generated. Allow a period for generating the SRQ.
70 The same with that of Program (2.2)
80 The same with that of Program (2.2)
90 The same with that of Program (2.2)
100
110 SRQ processing routine.
120 Disable SRQ reception.
130 Perform serial polling.
140 Timer
150 Clear device.
160 Display error message.
170 Enable SRQ reception again.
180 Go to statement 50 and receive next command.

```

Execution Example of Program (2.3)

① Setting state of CH1

COMMAND?	<u>CHANNEL1 COUPLING?</u> ↵
Abbreviation	<u>CH1 COU?</u> ↵
Display ex.	DC

② Setting state of MODE

COMMAND?	<u>MODE?</u> ↵
Abbreviation	<u>MOD?</u> ↵
Display ex.	REAL

③ To set to ATIME

COMMAND?	<u>ATIME?</u> ↵
Abbreviation	<u>ATI?</u> ↵
Display ex.	10US

Of other panels also, the functions of the controls can be dictated through the computer keyboard. The underlined items of the above commands are those to be manually entered through the keyboard. That is, all commands except "WAVE IN" and "WAVE OUT" can be given through the computer keyboard.

(4) Programming Example to Set Panel Controls and to Read Setting Values

This program is a modified one of Program (2.3) so that setting of panel controls also can be done.

Program (2.4)

```
10 DIM Command$[100],Dat$[100]
20 ABORT 7
30 REMOTE 7
40 ASSIGN @Com to 702
41 ON INTR 7 GOTO Srq_rou
42 ENABLE INTR 7;2
50 INPUT "COMMAND ?",Command$
60 OUTPUT @Com;Command$
61 WAIT .5
62 IF Command$[LEN(Command$)]<>"?" THEN 50
70 ENTER @Com;Dat$
```

885790

```

80 PRINT Dat$
90 GOTO 50
100 !
110 Srq_rou: !
120         DISABLE INTR 7
130         Stb=SPOLL(@Com)
140         WAIT .5
150         CLEAR @Com
160         PRINT "SRQ / GP-IB ERROR"
170         ENABLE INTR 7;2
180         GOTO 50
190 END

```

(Comments)

```

10 The same with that of Program (2.3)
20 The same with that of Program (2.3)
30 The same with that of Program (2.3)
40 The same with that of Program (2.3)
41 The same with that of Program (2.3)
42 The same with that of Program (2.3)
50 The same with that of Program (2.3)
60 The same with that of Program (2.3)
61
62 If the command is not of the type which calls for reading of
   setting value or other data, go to statement 50 and wait for
   the next command.
70 The same with that of Program (2.3)
80 The same with that of Program (2.3)
90 The same with that of Program (2.3)
100
110 SRQ processing routine
120 The same with that of Program (2.3)
130 The same with that of Program (2.3)
140 The same with that of Program (2.3)
150 The same with that of Program (2.3)
160 The same with that of Program (2.3)
170 The same with that of Program (2.3)
180 The same with that of Program (2.3)

```

885791

(5) Examples of Commands for Control of Cursors and Reading of Measured Values

Examples of commands for control of cursors and reading of values measured with cursors, using the program (2.4) are given below.

① "CURSOR MODE" command, with program of (2.4)

COMMAND?	<u>CURSOR MODE VOLT ↵</u>
Abbreviation	<u>CUR MOD VOL ↵</u>

② "CURSOR DELTA" command, with program of (2.4)

COMMAND?	<u>CURSOR DELTA 50 ↵</u>
Abbreviation	<u>CUR DEL 50 ↵</u>

Note: Even when in the remote mode, the cursors can be vernier-controlled with the READOUT control.

③ "CURSOR DATA?" command, with program of (2.4)

Moving the cursors with the READOUT control, read the measured value. COMMAND? CURSOR DATA? ↵

Abbreviation	<u>CUR DAT? ↵</u>
Display ex.	12.34 E-3

The underlined items of the above commands are those to be manually entered through the keyboard. For "↵", press the ENTER key.

(6) Examples of Commands for Control of DVM and Counter, and Reading of Measured Values

Examples of commands for control of the DVM and counter and reading of the measured values, using the program (2.4) are given below.

When in the remote mode with GP-IB, the DVM and the counter can be ON/OFF-controlled independently.

① "DVM MODE" command, with program of (2.4)

COMMAND?	<u>DVM MODE AC ↵</u>
Abbreviation	<u>DVM MOD AC ↵</u>

- ② "DVM DATA?" command, with program of (2.4)
- | | |
|--------------|-------------------|
| COMMAND?" | <u>DVM DATA?↵</u> |
| Abbreviation | <u>DVM DAT?↵</u> |
| Display ex. | 12.34 E-3 |
- ③ "COUNTER" command, with program of (2.4)
- | | |
|--------------|--------------------|
| COMMAND? | <u>COUNTER ON↵</u> |
| Abbreviation | <u>COU ON↵</u> |
- ④ "COUNTER DATA?" command, with program of (2.4)
- | | |
|--------------|-----------------------|
| COMMAND? | <u>COUNTER DATA?↵</u> |
| Abbreviation | <u>COU DAT?↵</u> |
| Display ex. | 12.34 E-6 |

The underlined items of the above commands are those to be manually entered through the keyboard. For "↵", press the ENTER key.

(7) Examples of Programs for Transfer of Waveform Data

This section introduces programs to send waveform data acquired in the storage mode to the host computer or other devices. The programs (2.1) through (2.4) are not usable for this purpose. Examples of programs for individual cases are shown below.

① Program to send data (binary) from oscilloscope to Model 9826 of HP

Program (2.5)

```

10 ABORT 7
20 REMOTE 7
30 ASSIGN @Com TO 702
40 INTEGER Wavdat (1023)
50 OUTPUT @Com;"MOD STO"
60 OUTPUT @Com;"PAU ON"
70 OUTPUT @Com;"WAV COD BIN"
80 OUTPUT @Com;" WAV OUT CH1"
90 ENTER @Com USING "%, B";Wavdat (*)
100 END

```

(Comments)

- 10 Initialize interface.
- 20 Set REN to true.
- 30 Assign attribute.
- 40 Declare array and secure data area.
- 50 Set to STORAGE mode.
- 60 Turn on PAUSE so that waveform data can be sent.
- 70 Specify binary for waveform data codes.
- 80 Request CH1 waveform output.
- 90 Enter transferred data item into array variable Wavdat (*), sequentially.

Remarks: Block Transfer

It also is possible to send only a part of the above waveform data, by dividing the total addresses into eight blocks by using the "WAVE START" and "WAVE END" commands, and by sending data in the unit of block. The relationships between data addresses and blocks are as shown in the following.

Block	0	Addresses	0 ~ 127
Block	1	Addresses	128 ~ 255
Block	2	Addresses	256 ~ 383
Block	3	Addresses	384 ~ 511
Block	4	Addresses	512 ~ 639
Block	5	Addresses	640 ~ 767
Block	6	Addresses	768 ~ 895
Block	7	Addresses	896 ~ 1023

Example: To read block 0 only

```
71 PRINT @Com; "WAV STA 0"  
72 PRINT @Com; "WAV END 0"
```

In this example the number of data addresses is 128. Therefore, "Wavdat (1023)" of statement 40 should be replaced with "Wavdat 127".

② Program to send data (binary) from Model 9826 to oscilloscope

For the above program it is assumed that the preceding program of (2.5) has been executed and waveform data has already been stored in Wavdat (*).

Program (2.6)

```
100 OUTPUT @Com;"MOD STO"  
110 OUTPUT @Com;"REF1 ON"  
120 OUTPUT @Com;"PAU ON"  
130 OUTPUT @Com;"WAV COD BIN"  
140 OUTPUT @Com;"WAV IN REF1"  
150 OUTPUT @Com USING "B";Wavdat(*) END  
160 END
```

(Comments)

```
100 Set to STORAGE mode.  
110 Turn on REFERENCE 1.  
120 Turn on PAUSE to transfer waveform data.  
130 Specify binary for waveform data codes.  
140 Specify waveform data entry to REFERENCE 1.  
150 Transfer data sequentially from array variable Wavdat (*).
```

As in the case of ①, part of waveform data can be sent by using

"WAVE START" and "WAVE END" commands.

(8) Step Control

This section introduces examples of programs for panel settings making use of step memory (0 - 99). In this simple method, programmable control for up to 100 types of oscilloscope panel settings can be realized.

① To write panel setting on step memory

Program (2.7)

```
10 ABORT 7  
20 ASSIGN @Com TO 702  
30 Stepno=0  
40 LOCAL 7
```

885795

```

50 PRINT "STEP No = " , Stepno
60 INPUT "PANNEL SET & HIT ENTER" , A$
70 Command$="STE "&VAL$(Stepno9&" WRI"
80 REMOTE 7
90 OUTPUT @Com;Command$
100 IF Stepno<99 THEN Stepno=Stepno+1
110 WAIT 1
120 GOTO 40
130 END

```

(Comments)

```

10 Initialize interface.
20 Assign attribute.
30 Initialize step number.
40 Set to LOCAL mode.
50 Display step number.
60 Set panel and wait for pressing of ENTER key.
70 Connect commands.
80 Set REN to true.
90 Write panel setting on step memory.
100 Increment step by 1.
110 Timer
120 Go to statement 40 and repeat setting.

```

(Note)

When in the LOCAL mode, even though you may adjust the vertical position, horizontal position, trigger level, holdoff, and trace separation controls, the adjustment data cannot be written on the memory. If you want to write the adjustment data on the step memory, adjust the controls in the REMOTE mode and then directly execute the step command without returning to the LOCAL mode.

② To read panel setting data on step memory

Program (2.8)

```

10 ABORT 7
20 REMOTE 7
30 ASSIGN @Com TO 702
40 INPUT "STEP No = " , Stepno
50 IF Stepno<0 OR Stepno>99 THEN 40
60 Command$="STE " &VAL$(Stepno)

```

885796

```
70 OUTPUT @Com;Command$
80 GOTGO 40
90 END
```

(Comments)

```
10 Initialize interface.
20 Set REN to true.
30 Assign attribute.
40 Enter step number.
50 Check step number.
60 Connect commands.
70 Read panel setting data which is written on step memory.
80 Go to statement 40 and repeat setting.
```

(9) Example of SRQ Processing

If the oscilloscope is set in a storage SINGLE TRIGGER STANDBY status, storing of waveform data in memory automatically starts as the triggering is effected. When storing in all addresses is over, an SRQ is generated. Thus, completion of data acquisition can be known by receiving the SRQ signal. An example of reception program is shown in the following.

Program (2.9)

```
10 ABORT 7
20 REMOTE 7
30 ASSINGN @Com TO 702
40 ON INTR 7 GOTO Acq_end
50 OUTPUT @Com;"MOD STO"
60 OUTPUT @Com;"PAU OFF"
70 OUTPUT @Com;"ATR MOD SIN"
80 ENABLE INTR 7;2
90 GOTO 90
100 !
110 Acq_end: !
120         DISABLE INTR 7
130         Stb=SPOLL(@Com)
140         PRINT "ACQUISITION END !"
150         WAIT 1
160         GOTO 70
170 END
```

885797

(Comments)

10 Initialize interface.
20 Set REN to true.
30 Assign attribute.
40 Specify processing routine to be followed when SRQ is
generated.
50 Set to STORAGE mode.
60 Release PAUSE.
70 Set to SINGLE TRIGGER STANDBY status.
80 Enable SRQ reception.
90 Wait for SRQ generation.
100
110 SRQ processing routine.
120 Disable SRQ reception.
130 Perform serial polling.
140 Timer.
150 Display acquisition completion message.
160 Go to statement 70 and set again to SINGLE TRIGGER STANDBY
status.

885798

7. INITIAL MODE SETTING AND DIAGNOSTIC FUNCTIONS

7.1 Initial Mode Setting

The oscilloscope is a microprocessor-based instrument and all of its functions are dictated by the microprocessor. When CPU operation has become abnormal due to external noise or other causes. It is reset to normal operation by performing initial mode setting.

For initial mode setting of COM7201E, COM7101E or COM7061A, press the SUB CURSOR SW ⑳ while keeping the 2ND FUNCTION KEY ㉓ pressed. For that of COM7200A, COM7100A or COM7060A, press the SUB CURSOR SW ㉑ while the CRT is in the beam find state after pressing once and releasing the INTEN control ㉒.

When initial mode setting is done, the oscilloscope is reset as follows:

COUPLING:	DC
VERT MODE:	CH1, CH2, ALT, BW ON
CH1, CH2 VOLT/DIV:	0.5V/DIV CH3, CH4 0.5V/DIV
TIME/DIV:	10 μ s/DIV
HORIZ MODE:	A
SWEEP MODE:	AUTO
TRIG SOURCE:	V-MODE CH1
TRIG LEVEL:	AUTO
TRIG CPLG:	AC
TRIG SLOPE:	"+"
CURSOR:	Δ T (50 μ s)
MODE:	REAL (for COM7201E, COM7101E and COM7061A only)

If the abnormal state is not remedied by the above initial mode setting, turn off the oscilloscope and then repeat the initial mode setting procedure.

If the abnormal state is not remedied still, check the conditions of use of the oscilloscope and, if they are found to be normal, consult your Kikusui agent.

7.2 Diagnostic Functions

The oscilloscope is incorporated with two types of self diagnostic functions: one is that automatically done when power is turned on and the other is that effected when the 2ND FUNCTION KEY ④③ is pressed.

When power of the oscilloscope is turned on, the contents of memory which stores data of panel setting and internal circuit calibration values are checked and, if any abnormal values are found, they are automatically adjusted to normal values (see Section 8.1). When the adjustment is over, the panel setting is identical with that effected by the initial mode setting and a message "INIT SYS DATA" is displayed at the center of the CRT. This message goes off as you press twice the INTEN control ②.

Other memory units than the above can be checked by pressing the READOUT control ③③ while keeping the 2ND FUNCTION KEY ④③ pressed. For COM7200A, COM7100A and COM7060A, the INTEN control ② acts as a second function key as in the case of initial mode setting. In this case, messages as shown in Figure 7.1 are displayed on the CRT for about 3 seconds.

If error messages as mentioned below are displayed when self diagnosis is done, if the same error messages are still displayed even when self diagnosis is repeated, or if self calibration is continuously repeated when power is turned on, check the conditions of use of the oscilloscope, and, if they are normal, consult your Kikusui agent.

- RAM ERR
- LED RAM ERR
- CHR RAM ERR
- ROM CHECK SUM ERR
- SEQ RAM ERR

885800

Note: "SUB CPU" and "GP-IB" are displayed for COM7201E, COM7101E and COM7061A only.

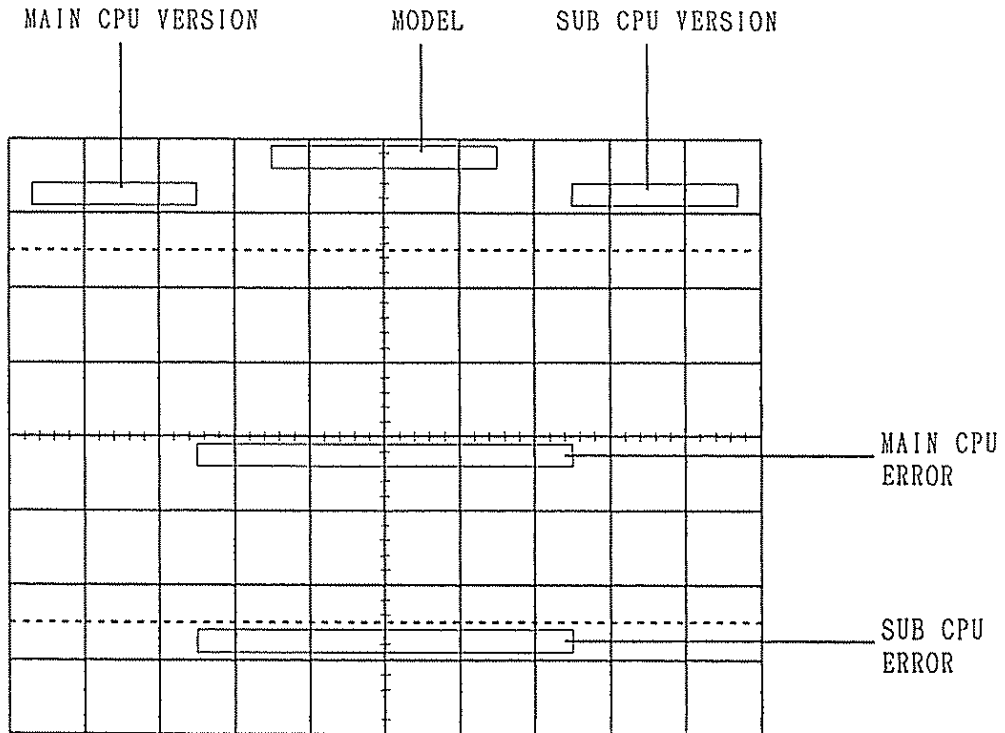

Figure 7.1 Diagnostic Messages Displayed on CRT

885801

8. CALIBRATION AND MAINTENANCE

8.1 Self Calibration

The basic functions of the oscilloscope, such as vertical axis DC offset, vertical axis deflection factor, and time base, are automatically adjusted by the microprocessor of the oscilloscope, eliminating the requirements of special calibration instruments and operator's skills. Calibration is accomplished rapidly.

For self calibration of COM7201E, COM7101E or COM7061A, press the DVM SW (34) while keeping pressed the 2ND FUNCTION KEY (43). For that of COM7200A, COM7100A or COM7060A, press the DVM SW (34) while the CRT is in the beam find status after pressing the INTEN control (2) and releasing it.

When self calibration is in progress, a message "SELF CAL" and the contents of calibration are displayed on the CRT. Calibration time is approximately 40 to 50 seconds for COM7200A, COM7100A or COM7060A, or approximately 2 to 5 minutes for COM7201E, COM7101E or COM7061A.

The items of self calibration are as follows:

- o CH1 and CH2 DC offset, position center, and deflection factor
- o A sweep and B sweep accuracies, and starting positions.
- o DELAY time compensator offset
- o DVM offset, sensitivity
- o Adjustment of storage circuit

When errors are more than can be corrected by the self calibration, a message "SELF CAL ERR" is displayed. Repeat the self calibration and if the state is not remedied, consult your Kikusui agent.

The self calibration should be done when the oscilloscope is warmed up and stabilized (when a stabilization period of 1 hour or over has elapsed after turning on power). Although self diagnosis will be done automatically when power is turned on, it is most recommendable to perform the self calibration when a stabilization period of 1 hour or over has elapsed.

885802

8.2 Inspection and Calibration

Although the oscilloscope is incorporated with automatic self calibration provision, it should be manually calibrated at appropriate intervals. Manual calibration of the oscilloscope requires special instruments and skills. It is recommended that your Kikusui agent for calibrate service of your oscilloscope.

Caution: Note that the oscilloscope employs a hazardously high voltage for its CRT and PCB.

8.3 Calibration Procedure

Calibration procedures of the oscilloscope are given below, excluding adjustment of high frequency characteristics and that of storage circuit. Do not attempt to make any adjustment other than those explained in the following.

(1) Removing the Case

To remove the case, proceed as follows: Remove the four studs (which act also as power cord takeups) and remove the rear panel. Holding the front panel, pull out the chassis unit from the case.

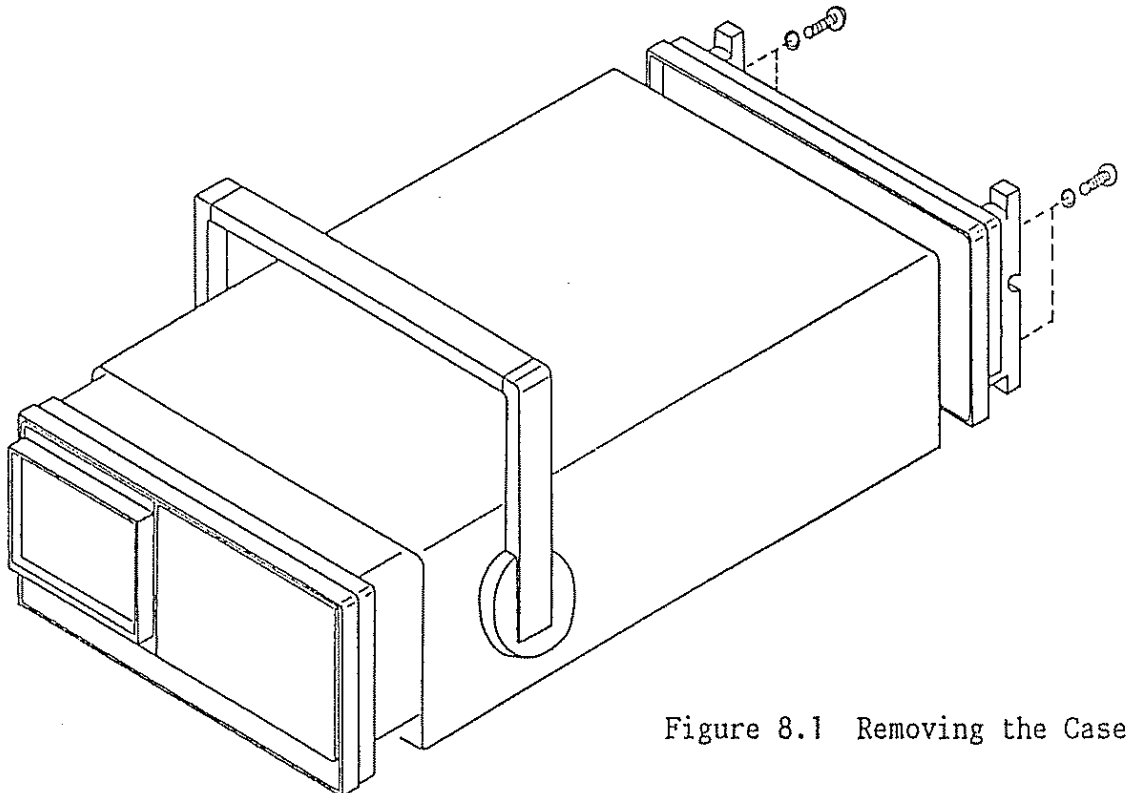

Figure 8.1 Removing the Case

(2) Check and Adjustment of Supply Voltages

The items to be checked first of all when calibrating the oscilloscope are supply voltages. If they are not within the tolerances, adjust the +12V supply voltage and then check other voltages.

Nominal Supply Voltage	COM7060A, COM7061A, COM7100A, COM7101E	COM7200A, COM7201E
+140 V	+135 to +145 V	+135 to 145 V
+70 V	+69 to +72 V	-
+40 V	-	+38 to +42 V
+12 V	+11.90 to +12.10 V	+11.90 to +12.10 V
+5 V (A)	+4.9 to +5.2 V	+4.9 to +5.2 V
+5 V (D)	+4.9 to +5.3 V	+4.9 to +5.3 V
-12 V	-11.90 to -12.10 V	-11.90 to -12.10 V
-2200 V	-2150 to -2250 V	-2150 to -2250 V

The locations of the check points and controls are shown in Figure 8.2. Those for the -2200V supply is on PCB A6.

Note: When supply voltages are changed, they substantially affect vertical deflection factors and sweep time base. Be sure to perform self calibration and adjustments of the subsequent items after adjusting the supply voltages.

885804

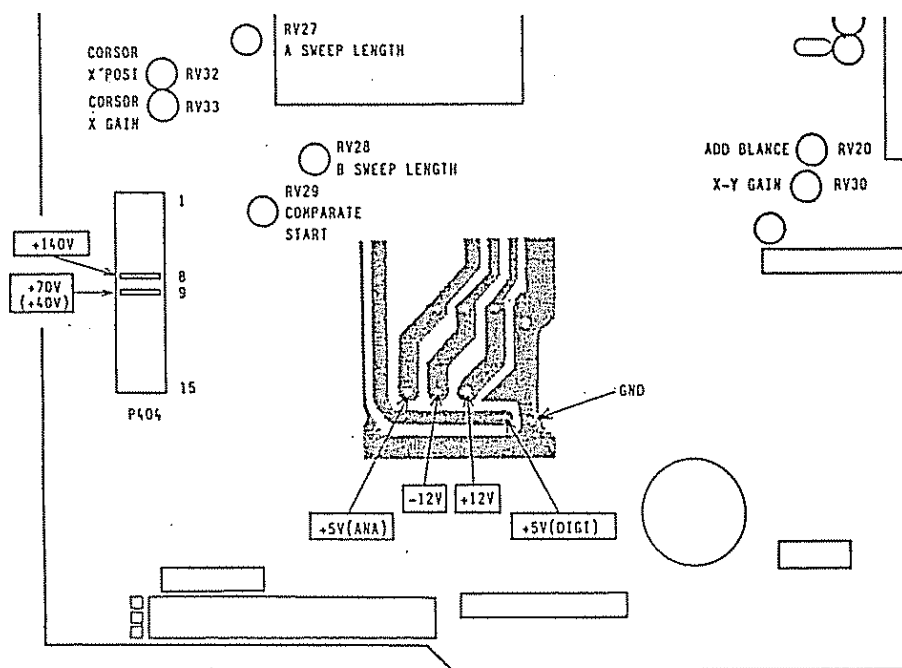

Figure 8.2 Locations of Supply Voltage
Check Points and Controls

(3) Adjustment of Vref 30mV

This voltage is used as a reference voltage for self calibration.
Adjust RV1 of PCB A4 so that the voltage across resistor R3 of PCB A4
becomes 30.01 to 29.99 mV.

885805

(4) Adjustment of CRT Circuits

o GEOMETRY

Adjust RV4 of PCB A6 so that the pattern displayed on the CRT becomes normal as shown in Figure 8.3.

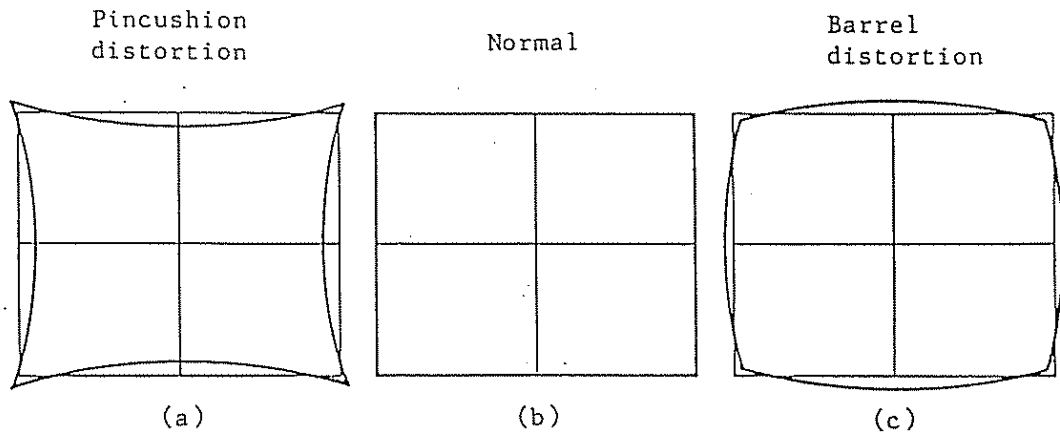

Figure 8.3 Patterns Displayed on CRT

o ASTIG HALATION

Display the beam spot at the center of CRT screen (X-Y mode) and the readout at peripheries, and adjust to best focussing the spot with the FOCUS control and ASTIG control (RV5 on PCB A6) and the readout with the FOCUS control and HALATION control (RV6 on PCB A6).

o SUB FOCUS

Set the FOCUS control at mid-position (noon position) and adjust RV3 of PCB A6 so that best focusing is obtained.

o SUB INTEN

Adjust RV2 of PCB A6 so that the spot (X-Y mode) disappears as the INTEN control is set at 10 o'clock position.

885805

(5) Adjustment of Vertical Axis (Y-axis) Gain

This adjustment is to adjust the Y-axis deflection factor to the self-calibrated value. Set the CH1 deflection factor to 10 mV/DIV, apply a calibration signal of 50 mV, and adjust RV3 of PCB A5 so that the signal is displayed with an amplitude of 5 DIV in the center of the CRT graticule.

(6) Adjustment of Horizontal Axis (X-axis) Gain

This adjustment is to adjust the X-axis deflection factor to the self-calibrated value. Set the time base at 1 ms/DIV, apply a time marker signal of 1 ms, and adjust RV7 of PCB A5 so that the 1st and 9th marker peaks are aligned with the corresponding graticule lines.

(7) Adjustment of Cursor X and Y GAIN and POSITION

Set ΔV cursor for the maximum vertical span and adjust RV21 of PCB A4 so that the cursor is displayed for 8 DIV on the CRT, and also adjust RV22 of PCB A4 so that the above state is attained with the POSITION control set at mid-position.

Set ΔT cursor for the maximum horizontal span and adjust RV33 of PCB A4 so that the cursor is displayed for 10 DIV on the CRT, and also adjust RV32 of PCB A4 so that the above state is attained with the POSITION control set at mid-position.

(8) Adjustment of ADD BAL

Adjust RV20 of PCB A4 so that the trace is displayed at the center of CRT when the traces of CH1 and CH2 are set at the center of CRT and the mode is changed to ADD.

885807

(9) Adjustment of TRIG LEVEL CENTER

Apply a 50-kHz sine wave and adjust RV25 (A TRIG) and RV26 (B TRIG) of PCB A4 so that the trace for TRIG AUTO starts from the center of CRT.

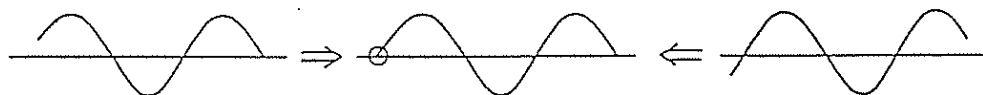

Figure 8.4 TRIG LEVEL CENTER

(10) Adjustment of TRIG DC OFFSET

Apply a 50-kHz sine wave to each of the channels, adjust the TRIG LEVEL control so that the trace starts at the center of CRT, and adjust the TRIG DC OFFSET control so that the starting point of trace does not change when the TRIG COUPLING switch is changed from AC to DC.

CH1	RV6 of PCB A4
CH2	RV8 of PCB A4
CH3	RV10 of PCB A4
CH4	RV12 of PCB A4

(11) Adjustment of CH3 GAIN and POSITION

Set the CH3 deflection factor to 0.1 V/DIV, apply a 0.5-V calibration signal, and adjust RV16 of PCB A4 so that the signal is displayed with an amplitude of 5 DIV on CRT. Next, set the INPUT COUPLING (A) switch to GND and adjust RV14 of PCB A4 so that the trace is displayed at the center of CRT with the CH3 POSITION control set at the mid position.

(12) Adjustment of CH4 GAIN and POSITION

In the same manner as in the case of CH3, adjust GAIN with RV17 of PCB A4 and POSITION with RV15 of PCB A4.

885808

(13) Adjustment of X-Y GAIN and CENTER

Set CH1 deflection factor at 10 mV/DIV, apply a 50-mV calibration signal, and adjust RV31 of PCB A4 so that the signal is displayed with an amplitude of 5 DIV in the X-Y mode.

Next, change the INPUT COUPLING ⑧ switch to GND and adjust RV30 of PCB A4 so that the spot is displayed at the center of CRT with the CH1 POSITION control ⑩ set at the mid position.

(14) Adjustment of CH1 SIG OUT OFFSET

Apply the CH1 SIG OUT (without 50-ohm termination) to the CH2 input. Set the CH2 deflection factor at 10 mV/DIV and adjust RV18 of PCB A4 so that the trace remains at the same position when the INPUT COUPLING ⑨ switch is changed from GND to DC.

(15) Adjustment of COMP START

Set the time base at 1 ms/DIV and check, by using a time marker signal, that the horizontal axis (X-axis) GAIN has been calibrated.

Set the A sweep to 1 ms/DIV and the B sweep to 10 μ s/DIV, set the readout to ΔT 8.000 ms, and set the DISPLAY A mode to ALT.

Set INPUT to GND and adjust RV29 of PCB A4 so that the distance between the two spots on the CRT becomes 8 DIV. Then perform self calibration.

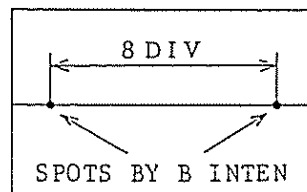

Figure 8.5 COMP START

885809

(16) Adjustment of SWEEP LENGTH

Set the time base at 1 ms/DIV and adjust RV27 (A sweep) and RV28 (B sweep) of PCB A4 so that the time base sweep length becomes 10.5 to 11.5 DIV.

(17) Adjustment of Time Base $\times 10$ MAG GAIN

Set sweep time at 1 ms/DIV $\times 10$ MAG, apply a 0.1-ms time marker signal, and adjust RV34 of PCB A4 so that the 1st and 9th peaks are aligned with the corresponding graticule lines.

(18) Adjustment of 5 ns, 2 ns, 1 ns COMPEN

For time base 50 ns, 20 ns, 10 ns/DIV $\times 10$ MAG (or 5 ns, 2 ns, 1 ns/DIV ranges), apply sine wave signal of 50 MHz, 100 MHz or 200 MHz, and adjust linearity and sweep time with RV8 and CV5 of PCB A5.
(Except COM7200A and COM7201E)

(19) Adjustment of ATT COMPEN Input Capacitance, and 1 mV COMPEN

Apply a 10-kHz pulse signal to each channel and adjust the ATT COMPEN and 1 mV COMPEN (CH1 and CH2) so that the displayed pulse wave rises up without overshoots or undershoots.

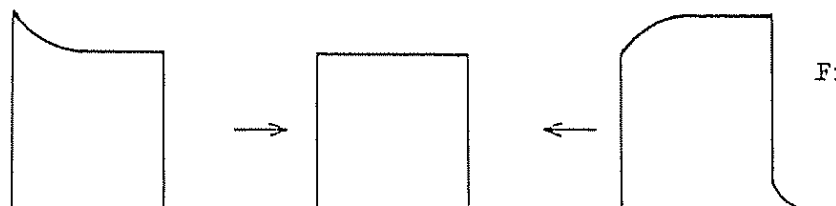

Figure 8.6
ATT COMPEN

	Adjustment of ATT COMPEN Input Capacitance and 1 mV COMPEN	
CH1, CH2	1/10 ATT (0.1 V/DIV)	1/100 ATT (1 V/DIV)
CH3, CH4	1/5 ATT (0.5 V/DIV)	

885810

Using a capacitance meter, adjust the input capacitance of attenuator of each channel to the same value with that of the reference range (1/1 ATT).

(20) Adjustment of DVM COMPEN

Adjust the CH1 deflection factor to 10 mV/DIV, apply a pulse wave of 50 mVp-p and 1 MHz, and measure the signal of U21 PIN NO. 16 using another oscilloscope. Adjust RV19 of PCB A4 so that the pulse wave rises up without overshoots or undershoots.

(21) Adjustment of Calibration Signal Voltage

Adjust RV1 of PCB A8 so that the voltage of the signal delivered to the CAL output terminal on the front panel of the oscilloscope becomes 0.5 Vp-p $\pm 2\%$.

885811

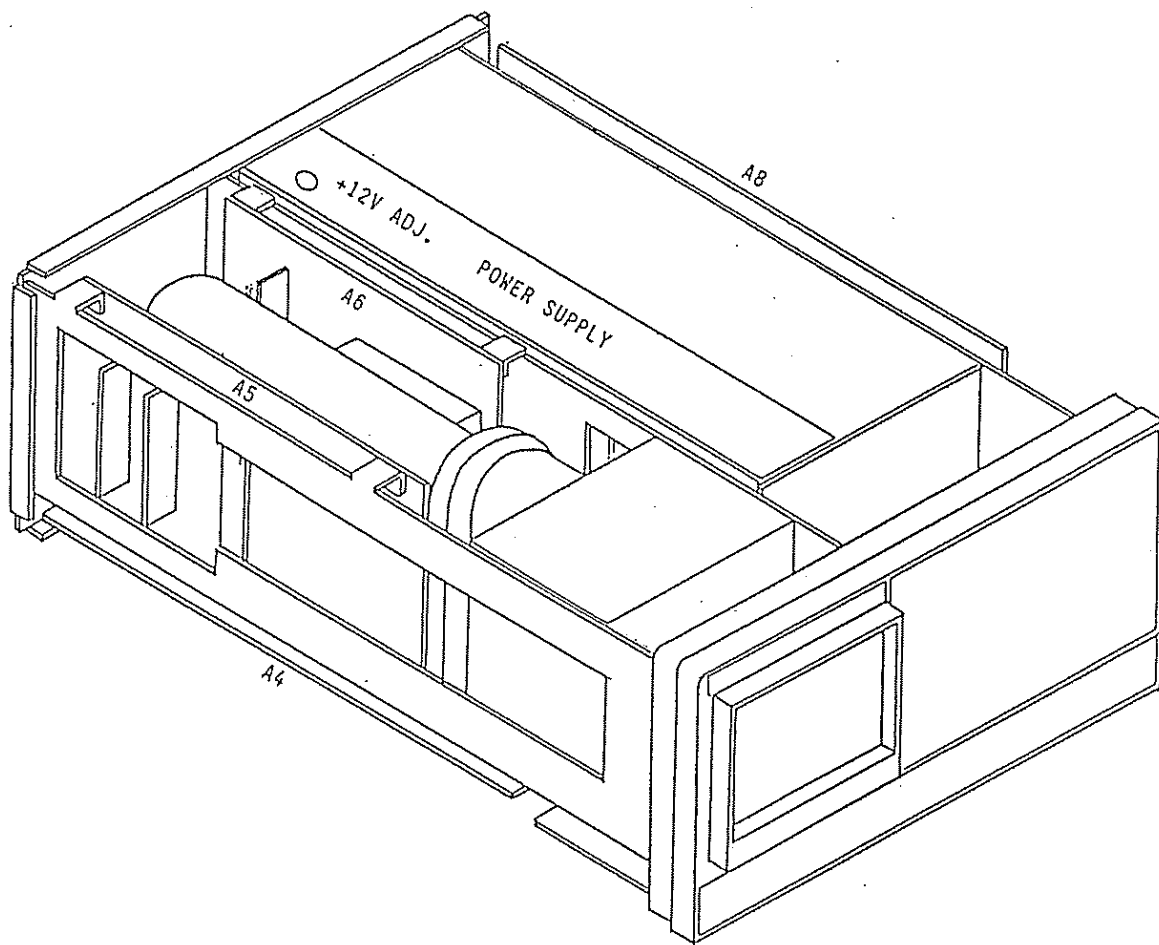

Figure 8.7 Locations of PCB's

885812

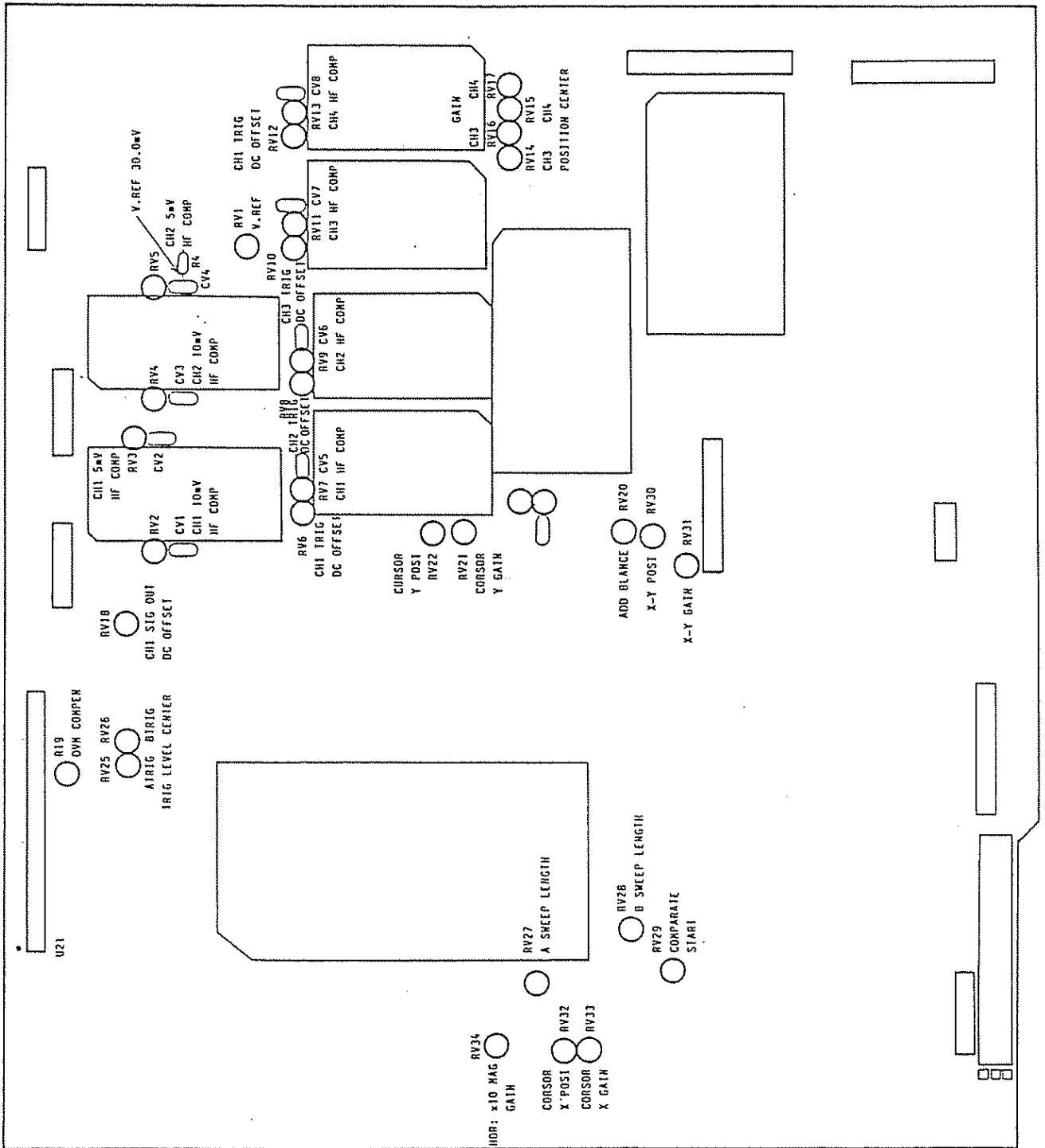

Figure 8.6 Layout of Controls on PCB A4

885813

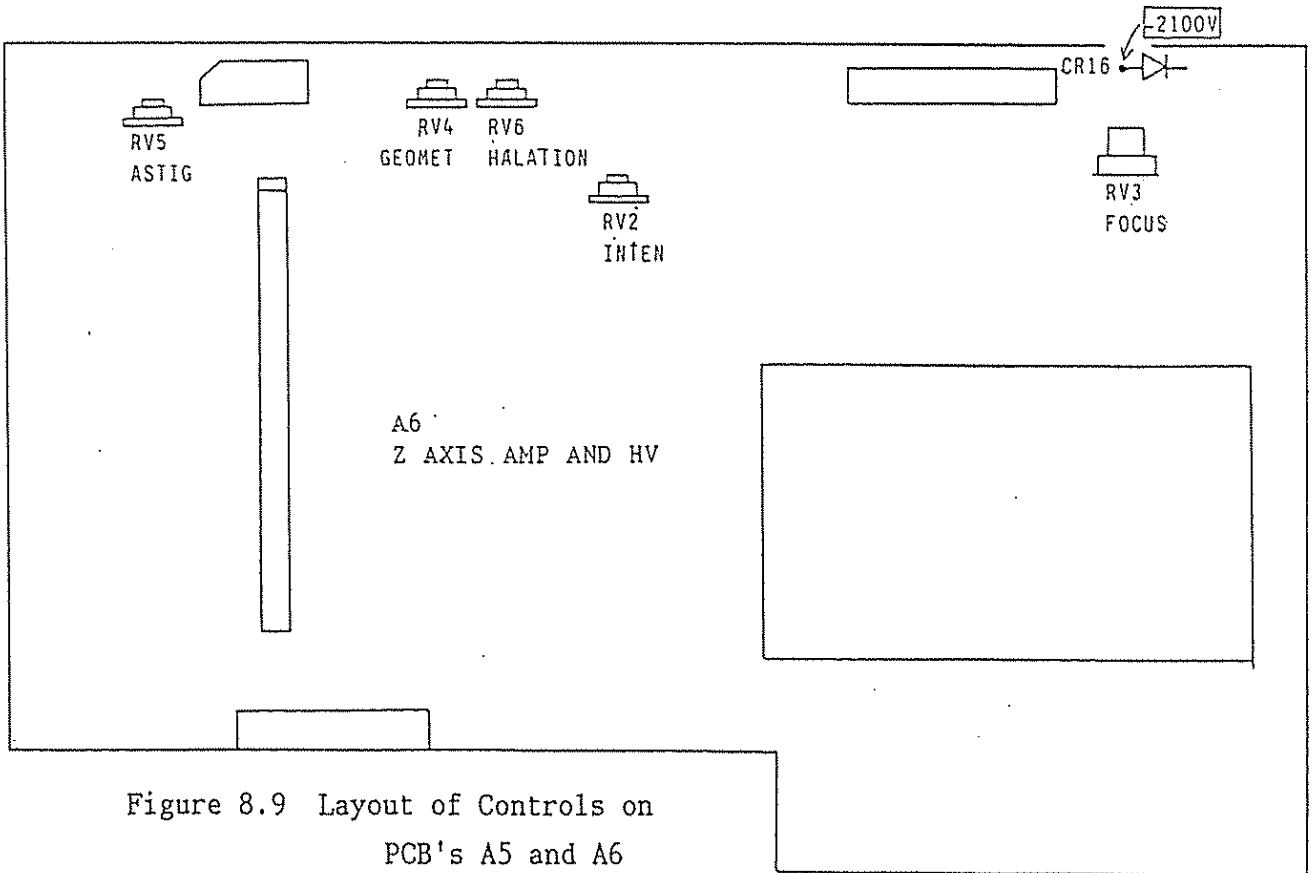
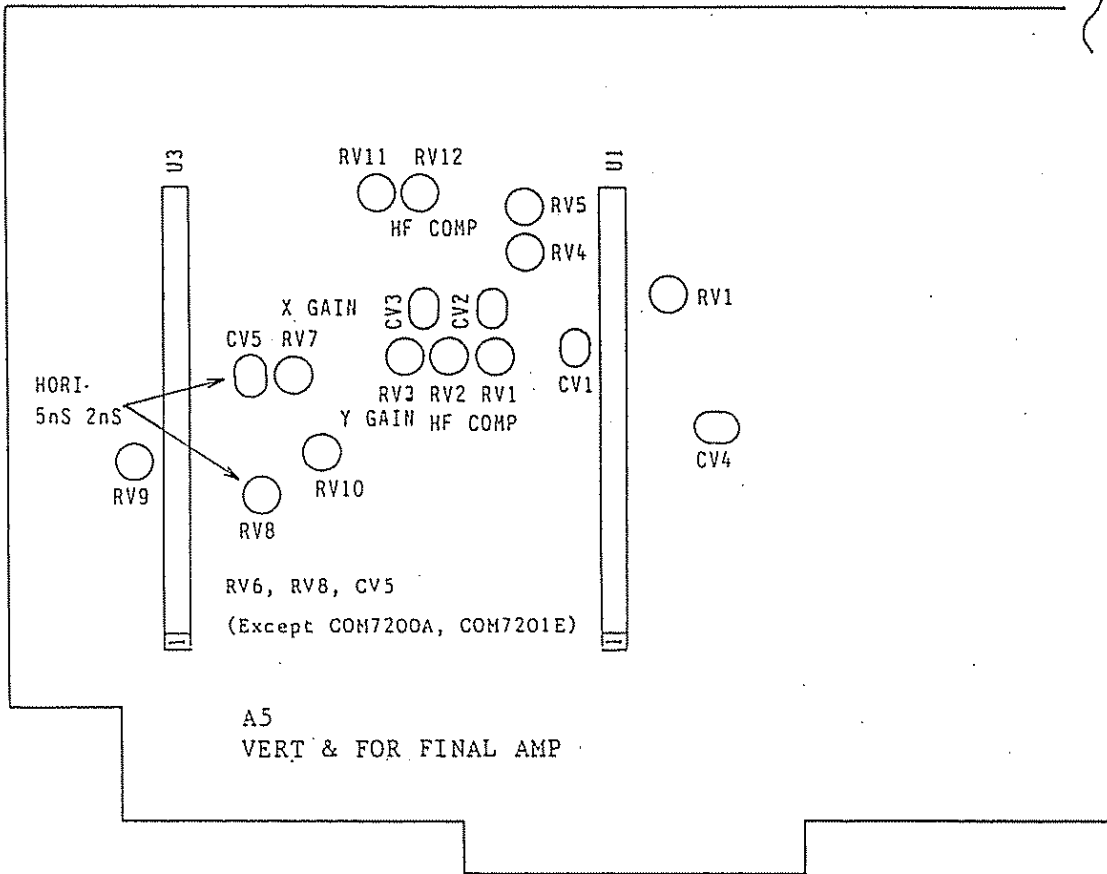
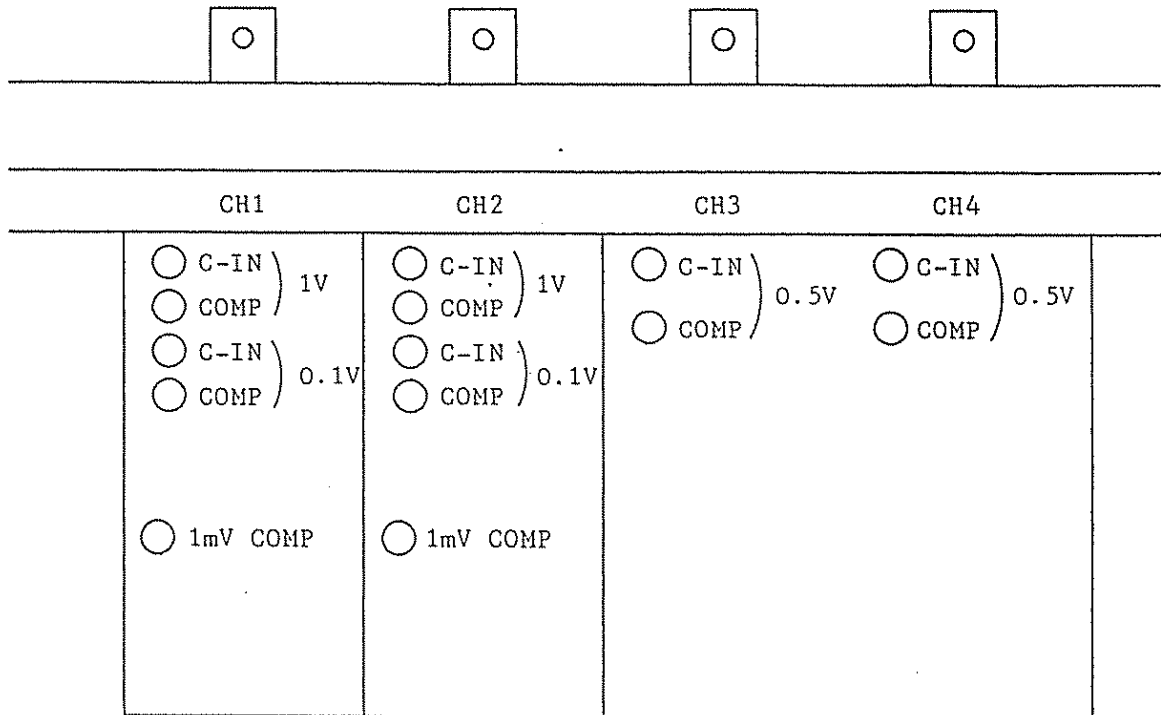

Figure 8.9 Layout of Controls on PCB's A5 and A6

885814



C-IN: Input capacitor

Figure 8.10 Locations of Attenuator Controls

885815